

TECHNICAL MANUAL

**OPERATION AND MAINTENANCE INSTRUCTIONS WITH
ILLUSTRATED PARTS BREAKDOWN
CHEMICAL-BIOLOGICAL MASK TYPE**

MCU-2A/P

MCU-2/P

PART NUMBERS

MINE SAFETY APPLIANCES

MCU-2A/P

MCU-2/P

88115010-10 MCU-2A/P SHORT

88115010-11 MCU-2A/P MEDIUM

88115010-12 MCU-2A/P LONG

88115001-10 MCU-2/P SHORT (KIT)

88115001-11 MCU-2/P MEDIUM (KIT)

88115001-12 MCU-2/P LONG (KIT)

(ATOS)

This publication supersedes T.O. 14P4-15-1 dated 30 June 2000, change 3 dated 5 August 2002.

DISTRIBUTION STATEMENT: Distribution authorized to US Government agencies and private individuals or enterprises eligible to obtain export-controlled technical data in accordance with regulations implementing 10 U.S.C. 140c (12 May 2003). Controlling DoD Office is WR-ALC/LKC, Robins AFB GA 31098. Questions concerning technical content should be directed to WR-ALC/LESGF.

WARNING: This document contains technical data whose export is restricted by the Arms Export Control Act (Title 22, U.S.C., Sec 2751 et seq.) or the Export Administration Act of 1979, as amended (Title 50, U.S.C., App. 2401 et seq.). Violations of these export laws are subject to severe criminal penalties. Disseminate in accordance with provisions of DoD Directive 5230.25.

HANDLING AND DESTRUCTION NOTICE: Comply with distribution statement and destroy by any method that will prevent disclosure of the contents or reconstruction of the document.

LIST OF EFFECTIVE PAGES

NOTE: The portion of the text affected by the changes is indicated by a vertical line in the outer margins of the page. Changes to illustrations are indicated by miniature pointing hands. Changes to wiring diagrams are indicated by shaded areas.

Dates of issue for original and changed pages are:

Original 0 12 May 2003

TOTAL NUMBER OF PAGES IN THIS MANUAL IS 76, CONSISTING OF THE FOLLOWING:

Page No.	*Change No.	Page No.	*Change No.	Page No.	*Change No.
Title	0				
A	0				
i - iii	0				
iv Blank	0				
v - vi	0				
1-1 - 1-4	0				
2-1	0				
2-2 Blank	0				
3-1 - 3-8	0				
4-1 - 4-11	0				
4-12 Blank	0				
5-1 - 5-23	0				
5-24 Blank	0				
6-1 - 6-7	0				
6-8 Blank	0				
A-1 - A-2	0				
B-1 - B-4	0				
C-1 - C-2	0				
D-1	0				
D-2 Blank	0				

*Zero in this column indicates an original page

TABLE OF CONTENTS

Chapter	Page	Chapter	Page
LIST OF ILLUSTRATIONS	ii	4.1	Theory of Operation.....4-1
LIST OF TABLES	ii	4.2	Inhalation
FOREWORD	iii	4.3	Exhalation
SAFETY SUMMARY	v	4.4	Voice Communications
1 GENERAL INFORMATION.....	1-1	4.5	Left-handed Use
1.1 General Information	1-1	4.6	Drinking Tube.....
1.2 Mask Purpose	1-1	4.7	Carrier
1.3 Features	1-1	4.8	Operating Instructions
1.4 Description	1-1	4.13	Donning Procedures
1.5 Components	1-1	4.14	Donning Procedures for Masks with Attached Hoods
1.6 Mask Markings	1-2	4.15	Donning Procedures for Mask Only.....
1.7 Accessories	1-2	4.16	Doffing Procedures.....
1.8 MCU-2A/P Facepiece Assembly	1-2	4.17	Doffing Procedures for Masks with Attached Hoods
1.9 MCU-2/P Kit	1-2	4.18	Doffing Procedures for Mask Only.....
2 SPECIAL TOOLS AND TEST EQUIP- MENT	2-1	4.26	Limitations
2.1 General	2-1	4.27	Decontamination.....
2.2 Special Tools Required	2-1	5 MAINTENANCE INSTRUCTIONS	5-1
3 PREPARATION FOR USE AND SHIP- MENT.....	3-1	5.1	Operational Checkout.....
3.1 Preparation for Use.....	3-1	5.2	Inspection and Preventive Mainte- nance
3.2 Unpacking.....	3-1	5.3	Repair.....
3.3 Checking Unpacked Original Equipment	3-1	5.4	Disassembly
3.4 Selection of Mask Size.....	3-1	5.5	Cleaning and Disinfecting Mask.....
3.5 Mask Fitting.....	3-3	5.7	Repair or Replacement
3.6 Drink Tube Leak Check.....	3-4	5.8	Head Harness/Skull Cap Replace- ment.....
3.7 Negative Pressure Check.....	3-4	5.9	Side Voicemitter Replacement.....
3.8 Accomplish Quantitative Fit Training (QNFT).....	3-4	5.10	Outlet Valve Cover Replacement
3.9 Canister Conversion Option.....	3-5	5.11	Outlet Valve Disc Replacement.....
3.10 Hoods w/o Neck Cord, Underarm Straps or Temple Straps	3-5	5.12	Inlet Valve Assembly Replace- ment.....
3.11 Stowing Mask and Hood for Op- erational Use	3-5	5.13	Nosecup Valve Disc Replacement
3.12 Long Term Storage.....	3-6	5.14	External Drinking Tube Replace- ment.....
3.13 Preparation for Shipment	3-6	5.15	Internal Drinking Tube Replace- ment.....
3.14 Pre-packing Inspection	3-6	5.16	Nosecup Valve Seat Replacement
3.15 Packing.....	3-6	5.17	Re-torquing/Replacement of the Front Voicemitter (Figure 6-1, Index 18).....
4 OPERATION INSTRUCTIONS	4-1	5.18	M101/A1C or Similar Type Microphone Installation.....
		5.19	Outsert Rubber Strap Replace- ment.....
		5.20	MCU-2 Series Second Skin
		5.21	Detachable Microphone Instruc- tions
		5.22	Removing Detachable Microphone.....

T.O. 14P4-15-1

6	ILLUSTRATED PARTS BREAKDOWN.....	6-1	B	PREPARATION FOR USE AND SHIP- MENT.....	B-1
6.1	General.....	6-1	B.1	HGU-65P Explosive Ordnance Dis- posal (EOD) Hood Attachment	B-1
6.2	Purpose.....	6-1	B.2	Storage	B-1
6.3	Introduction.....	6-1	C	OPERATION INSTRUCTIONS	C-1
6.4	Group Assembly Parts Lists.....	6-1	C.1	Donning Procedures for Masks with HGU-65P EOD Hoods.....	C-1
6.5	Maintenance Parts List.....	6-1	C.2	Doffing Procedures for Masks with HGU-65P EOD Hoods.....	C-2
6.6	Models Covered.....	6-1	C.3	HGU-65/P Cleaning	C-2
6.7	Abbreviations and Symbols	6-1	C.4	MCU-2 Series Mask Cleaning	C-2
6.8	Commercial and Government En- tity (CAGE)	6-1	D	MAINTENANCE INSTRUCTIONS	D-1
6.9	Numerical Listing	6-1	D.1	Inspection and Preventive Mainte- nance of the HGU-65P EOD Hood.....	D-1
6.10	Alphabetical Listing	6-2	D.2	Repair	D-1
6.11	Usable on Code Column	6-2			
6.12	Source, Maintenance and Recov- erability (SMR) Codes.....	6-2			
6.13	Applicable Time Compliance Technical Orders (TCTO).....	6-2			
A	INTRODUCTION AND GENERAL IN- FORMATION	A-1			
A.1	HGU-65P Description	A-1			

LIST OF ILLUSTRATIONS

Number	Title	Page	Number	Title	Page
1-1	MCU-2P and MCU-2A/P Protective Mask	1-3	5-2	Cleaning	5-8
1-2	Mask Accessories	1-4	5-3	Side Voicemitter Replacement.....	5-11
3-1	Facial Measuring Points	3-1	5-4	Outlet Valve Cover Replacement	5-12
3-2	MCU-2A/P Sizing Scale	3-2	5-5	Outlet Valve Disc Replacement.....	5-13
3-3	Adjusting Straps.....	3-4	5-6	Inlet Valve Assembly Replacement.....	5-13
3-4	Attaching Hood to Mask.....	3-6	5-7	Nosecup Valve Disc Replacement.....	5-14
3-5	Stowed in Carrier (Operational).....	3-7	5-8	External Drinking Tube Replacement.....	5-15
3-6	Inlet Valve Assembly	3-7	5-9	MCU-2A/P Microphone Installation.....	5-17
3-7	Side Voicemitter Assembly	3-8	5-10	Optional Drink Tube Adapter	5-19
4-1	MCU-2 Series Air Flow	4-3	5-11	Second Skin	5-20
4-2	Mask Carrier Wear	4-4	5-12	Front Voicemitter Inspection.....	5-21
4-3	Hood Donned.....	4-6	6-1	MCU-2 Series Mask (Including Acces- sories).....	6-3
4-4	Drinking Tube Use	4-8	A-1	HGU-65P EOD Hood	A-2
4-5	Waterproofing Bag Use.....	4-9	B-1	Voicemitter Grommet Position	B-2
4-6	Freeing Stuck Outlet Valve Disc.....	4-10	B-2	C-2 Canister Grommet Position.....	B-3
4-7	Carrier Stowing Pockets.....	4-10	B-3	HGU-65P Folding Procedures.....	B-4
5-1	MCU-2P and MCU-2A/P Mask Inspec- tion.....	5-5			

LIST OF TABLES

Number	Title	Page	Number	Title	Page
5-1	Inspection and Preventive Maintenance Checks.....	5-1	D-1	Inspection and Preventive Maintenance Checks.....	D-1

FOREWORD

1. PURPOSE OF MANUAL.

This manual describes the operation and maintenance instructions and illustrated parts breakdown for the Mask Canister Unit-Personnel, type MCU-2 Series. This manual complies with STANAG 2150.

TM 3-4230-235-10

Operator's Manual For Decontamination Kit, Individual Equipment: M295

2. SCOPE OF MANUAL.

The information contained in this manual will be followed by all users of the MCU-2 Series.

T.O. 00-5-1

AF Technical Order System

TO 00-25-195

Joint Military Services Uniform Source, Maintenance, and Recovery (SMR) Codes

T.O. 00-35D-54

USAF Material Deficiency Reporting System

3. IMPROVEMENT REPORT.

Improvements to this technical manual shall be made in accordance with T.O. 00-5-1 and sent to HQ AFCESA/CEX 139 Barnes Dr., Ste. 1, Tyndall AFB, FL 32403-5319.

T.O. 11D1-1-111

Operation and Maintenance Instructions, Decontaminating Kit Personal, M258A1

T.O. 11D1-1-131

Operation and Maintenance Instructions, Decontaminating Kit Personal, M291.

4. RELATED PUBLICATIONS.

The following is a list of related publications.

AFI 32-4001	Disaster Preparedness Planning and Operations
AFMAN 32-4005	Personal Protection and Attack Actions
AFMAN 32-4006	Nuclear, Biological, and Chemical (NBC) Mask Fit and Liquid Hazards Simulant Training

T.O. 14P4-15-11

Operator and Unit Maintenance Manual for Protection Assessment Test System, M-41

T.O. 14P4-1-151

Chemical-Biological Canisters and Filter Element Procedures and Serviceability List.

SAFETY SUMMARY

1. This technical manual contains CAUTIONS and WARNINGS applicable to the use of the MCU-2 Series mask. Before using the mask, personnel should be aware of the hazards which could be encountered, especially in a contaminated environment. Special attention to the instructions in this manual will assure safe wear of the MCU-2 Series series protective mask and accessories.

2. WARNING.

An operating or maintenance procedure, practice, condition, statement, etc., which, if not strictly observed, could result in injury or death of personnel.

3. CAUTION.

An operating or maintenance procedure, practice, condition, statement, etc., which, if not strictly observed, could result in damage to or destruction of equipment or loss of mission effectiveness.

4. USE OF SHALL, WILL, SHOULD AND MAY.

- a. SHALL OR WILL: "Shall or will" indicates a mandatory requirement.
- b. SHOULD: "Should" is used to indicate a non-mandatory desire or preferred method of accomplishment.
- c. MAY: "May" is used to indicate an acceptable or suggested means of accomplishment.

5. The following warnings and cautions appear in the text of this manual and are repeated here for emphasis:

WARNING

For initial mask fit, use the caliper to measure the face length. The use of a ruler or tape measure will lead to inaccurate reading due to the contour of the face. A leaking mask will not protect against toxic agents which can cause illness or death.

WARNING

Do not hold mask by canister. A canister which has unscrewed may allow toxic agents to enter the mask which can cause illness or death.

WARNING

You must check the mask for leaks when it is fitted and each time you put it on. A leaky mask will not protect you from toxic agents which can cause illness or death.

WARNING

If resistance is not felt when blowing into or sucking through the drinking tube, a leak is present and toxic agents may enter the mask.

WARNING

Perform the steps for putting on your mask quickly. You must put the mask on before you take another breath. Toxic agents may be in the surrounding air and can cause illness or death.

WARNING

Do not store food in the waterproofing bag. Possible toxic effects may result.

WARNING

The MCU-2 Series mask is not an authorized respiratory device for industrial chemical use. The chemical biological filter canister will not protect against ammonia or carbon monoxide, and the mask is not effective in confined spaces where there is not enough oxygen in the air to support life.

WARNING

When wearing the mask with the hood over outlet valve (Figure 4-3), do not loosen the straps of the head harness for comfort. When straps are loosened, the wearer is in danger of suffocation by carbon dioxide and unprotected against toxic agents.

WARNING

If you become overheated in cold weather, when possible do not remove your mask outdoors until your head cools and any sweat has dried. Frostbite may result if the mask is removed while your face is still wet.

WARNING

With suspected presence of contamination, don your mask immediately. You must put the mask on before you take another breath. Toxic agents may be in the surrounding air and can cause illness or death.

WARNING

Make sure side voicemitter is installed with the flange and four pins facing outward (Figure 3-7, view D). Incorrect installation may result in leakage of toxic agents into the mask causing illness or death.

WARNING

The side voicemitter must be installed using a serviceable gasket. Use of an UNSERVICEABLE gasket could result in leakage of toxic agents causing illness or death.

WARNING

A serviceable C-2 series canister must be installed in the MCU-2 Series mask prior to use in a toxic chemical or biological environment.

WARNING

Failure to perform the Negative Pressure Check may result in illness or death due to exposure to chemical agents.

WARNING

Contact lenses shall not be worn with this mask.

WARNING

Failure to loosen the bottom straps on the mask prior to removing the mask will place excessive and undue stress on the outlet valve assembly. This stress on the outlet valve assembly will contribute to disbonding of the mask.

WARNING

When in a contaminated environment, pressure shall be applied to the front voicemitter (using two fingers) prior to removing the hood to prevent mask seal from being broken. Breakage of the mask seal can cause illness or death.

CHAPTER 1

GENERAL INFORMATION

1.1 GENERAL INFORMATION.

1.2 MASK PURPOSE.

The MCU-2 Series with a serviceable canister installed protects the face, eyes, and respiratory tract from chemical and biological warfare agents and radioactive dust particles.

1.3 FEATURES.

The MCU-2 Series has the following features:

- a. The mask provides user with eye and respiratory protection.
- b. The mask has two voicemitters; the front one is for face-to-face speech and the side one is for use with communications equipment.
- c. The mask is equipped with a drinking tube. This enables user to drink from a canteen having an M1 canteen cap.
- d. The mask can be worn with approved mask-compatible spectacles.
- e. The flexible lens permits use of binoculars, a gunsight, or other optical equipment.
- f. The large single lens gives user a good all around view.
- g. The canister (filter) can be used on either side of the mask as desired. (See conversion, paragraph 3.9.)
- h. There are three mask sizes. These are identified by raised letters on the mask above lens, S for short, M for medium, and L for long.
- i. Internal and external microphone connectors (MCU-2A/P only).

1.4 DESCRIPTION.

1.5 COMPONENTS.

The MCU-2 Series (Figure 1-1) consists of the following components.

- a. Facepiece - The facepiece is molded of silicone rubber. It forms an effective seal on the user's face.

- b. Lens - The lens is molded of an optically clear urethane material. It provides a distortion-free view. The lens is bonded onto the facepiece.
- c. Head harness - Six metal-tip elastic straps are attached to the facepiece tabs by buckles. A webbing headpad joins the straps together and holds them in the correct position. A quick don pull tab is sewn to the headpad.
- d. Skull Cap - Six metal-tip elastic straps are attached to the facepiece assembly tabs by buckles. The straps are attached to a mesh cap that covers the crown of the head and holds the mask in the correct position.
- e. Nosecup - The nosecup is molded of silicone rubber. It is located inside the facepiece. It is attached to the front voicemitter housing and seals around the outlet valve.
- f. Voicemitters - Two plastic discs in protective metal cases. They are located in the center and on one side of the facepiece. The side voicemitter and a rubber gasket are held in place by a threaded retaining ring. MCU-2A/P front voicemitter/micmitter is equipped with connections for an internal microphone connector and an external communication connection.
- g. Nosecup Valves - Two plastic one-way valve bodies with silicone rubber valve discs on each side of the nosecup.
- h. Inlet Valve Assembly - A one-way valve at the side of the facepiece behind the canister. Consists of a plastic air deflector assembly with post mounted rubber valve disc and a rubber valve body.
- i. Outlet Valve Assembly - A one-way valve at the bottom of the facepiece. Consists of a metal tube and valve body and a rubber valve disc.
- j. Outlet Valve Cover - A rubber cover which fits over the end of the outlet valve body. The cover has a pocket which holds the drinking tube coupling.
- k. C₂ Series Canister - The canister contains material to filter Chemical and Biological agents and radioactive dust particles from the air. The canister screws into the inlet valve body. The canister utilizes a NATO standard thread. Filter elements will be replaced as directed by T.O. 14P4-1-151.

T.O. 14P4-15-1

- l. External Drinking Tube - The external drinking tube is a rubber tube connected to a metal feed-through pipe on the outside of the outlet valve body. The external drink tube is field replaceable. A quick disconnect coupling is attached to the other end of the external drink tube. This coupling mates with the M1 canteen cap.
- m. Internal Drinking Tube - The internal drinking tube is a rubber tube connected to a metal feed through pipe on the inside of the outlet valve body. The internal drink tube is field replaceable.
- n. Outserts - The outserts are optically clear and tinted polycarbonate shells. The outserts protect the lens from scratches when the mask is stored in its carrier. The outserts also protect the lens from chemical droplets and oil and petroleum products when the mask is worn. Clips at the top and a rubber strap at the bottom hold the outsert onto the facepiece. Outserts are issued in two sizes: short and medium/long and are identified as such. Short outserts fit short masks. Medium/long outserts fit medium or long masks.
- b. Field Protective Hood - The field protective hood is made from rubber coated nylon cloth. The hood has underarm straps which hold the hood in place, an adjustable neck strap to aid in hood pressurization, and two snap-fastening temple tab straps for attaching the hood to the mask temple tabs. The face opening in the hood is made to fit tightly around the lens.
- c. Waterproofing Bag - The waterproofing bag is a sealable plastic bag, stowed in the carrier and used to protect the mask from moisture in wet and damp conditions. Waterproofing bag is an optional accessory.
- d. Voice Projection Unit - Voice projection units are available for use as an optional accessory. They are designed to improve communications with others in close proximity to the user.

NOTE

Wearing of the outsert is mandatory and is not an optional item.

1.6 MASK MARKINGS.

Identification markings on the MCU-2 Series are as follows:

- a. Manufacturer - The manufacturer is identified on the facepiece by a raised circular medallion located near the left neck strap.

NOTE

The numbers located within the medallion are used during manufacture and are **NOT** lot numbers.

- b. Lot number - The lot number is printed or laser etched on a neck tab.

1.7 ACCESSORIES.

Accessories (Figure 1-2) consists of the following items:

- a. Carrier - The carrier is made of mildew resistant nylon. It has adjustable waist and shoulder straps. Pockets are provided inside and outside the carrier to hold other accessories.

1.8 MCU-2 SERIES FACEPIECE ASSEMBLY.

When ordering the facepiece assembly, it will automatically come with the following components:

- a. Harness, Head or Skull Cap
- b. Air Deflector Assembly
- c. Disc, Inlet Valve
- d. Body, Inlet Valve
- e. Drinking Tube, External
- f. Cover, Outlet Valve
- g. Disk, Outlet Valve
- h. Front Voicemitter
- i. Voicemitter, Side
- j. Gasket, Side Voicemitter
- k. Disc, Nosecup Valve
- l. Drinking Tube, Internal
- m. Valve, Nosecup Seat
- n. Internal and External microphone (MCU-2A/P only)

1.9 MCU-2/P KIT.

The MCU-2/P kit contains a carrier, clear outsert, hood and all components listed in paragraphs 1.8a through 1.8n.

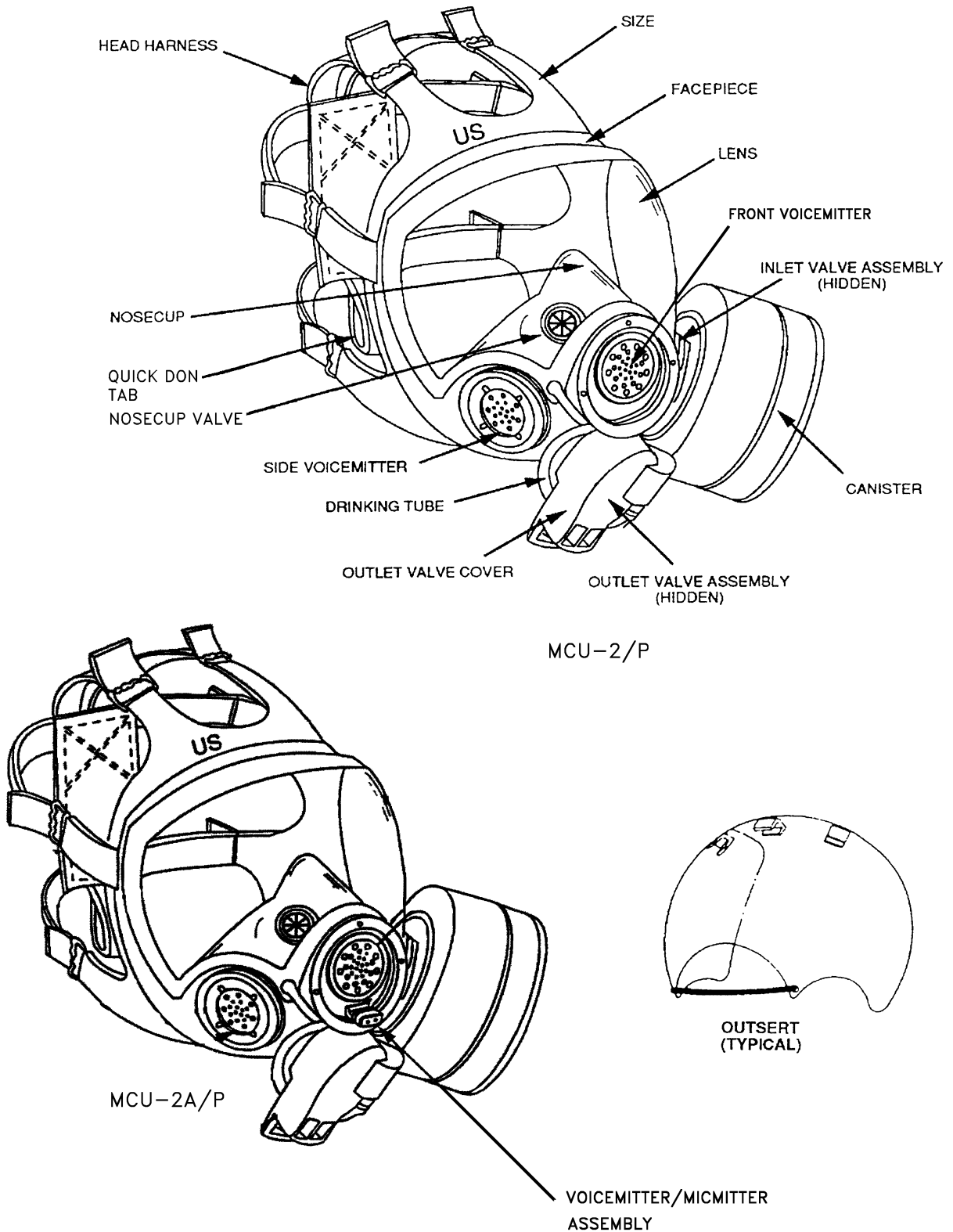
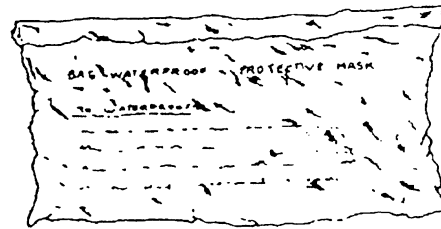
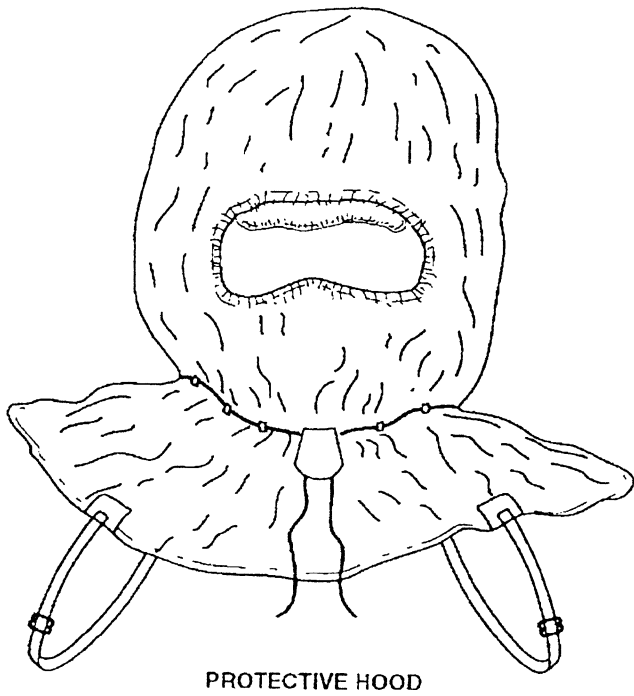
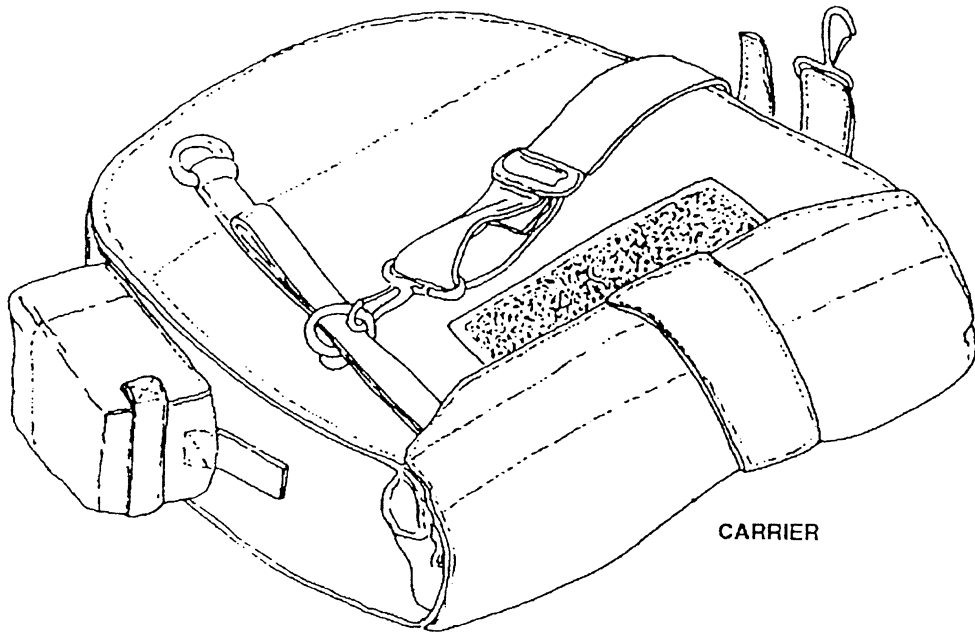

Figure 1-1. MCU-2P and MCU-2A/P Protective Mask

L0003739



WATERPROOFING BAG
(OPTIONAL)

L0003740

Figure 1-2. Mask Accessories

CHAPTER 2

SPECIAL TOOLS AND TEST EQUIPMENT

2.1 GENERAL.

This chapter describes the special tools and test equipment used to perform maintenance on the Chemical-Biological Mask.

2.2 SPECIAL TOOLS REQUIRED.

2.3 The special tools required are listed below:

- a. Six inch Calipers
- b. Front Voicemitter Tool, part No. 200224199, Cage 98752
- c. Torque Wrench, 3/8 inch male drive, 30-150 in - lb graduated, NSN 5120-01-396-6017
- d. TDA 99M or an approved Joint Service Mask Leakage Tester (JSMLT)
- e. M41, Protection Assessment Test System

CHAPTER 3

PREPARATION FOR USE AND SHIPMENT

3.1 PREPARATION FOR USE.

3.2 UNPACKING.

Remove mask and components from shipping container.

3.3 CHECKING UNPACKED ORIGINAL EQUIPMENT.

Inspect the equipment for damage following criteria in Table 5-1. Report damage according to T.O. 00-35D-54, USAF Material Deficiency Reporting and Investigating System.

3.4 SELECTION OF MASK SIZE.

Initial mask size selection is determined by a face length measurement. The use of any 6-inch calipers, is required to measure the user's face length.



Use a caliper to measure the face length. The use of a ruler or tape measure will lead to an inaccurate reading due to the contour of the face. A leaky mask will not protect against toxic agents which can cause illness or death.

- a. Accurate location and marking of the two facial measuring points is necessary to assign correct mask size. The two points are described below and depicted in Figure 3-1. Read descriptions and study the figure carefully before attempting to locate the two points on user's face. The points can be located either by visual inspection or by feel.
 - (1) The upper measuring point is the point of deepest depression at top of nose, between the eyes (Figure 3-1).
 - (2) The lower measuring point is located at the center of the curved part of jaw bone (tip of chin; Figure 3-1).
- b. Have the user sit erect with head held level and still, mouth closed, and teeth lightly together.

- c. Carefully locate and mark upper and lower measuring points.
- d. Place upper and lower tips of the caliper directly on the upper and lower points marked as directed in step c.
- e. To determine the initial mask size with any 6-inch caliper, see Figure 3-2 for sample MCU-2 Series Sizing Scale.

NOTE

A sizing scale can be made by utilizing the measurements provided in the sample scale in Figure 3-2.

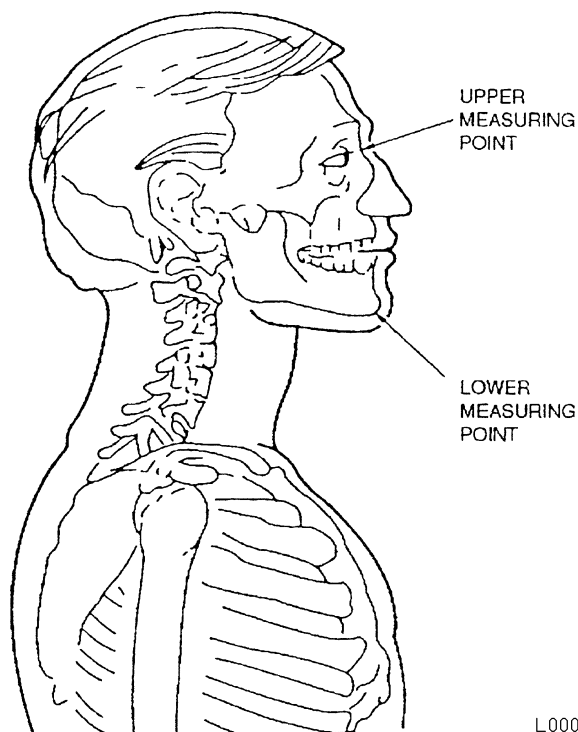

L0003741

Figure 3-1. Facial Measuring Points

MCU-2A/P

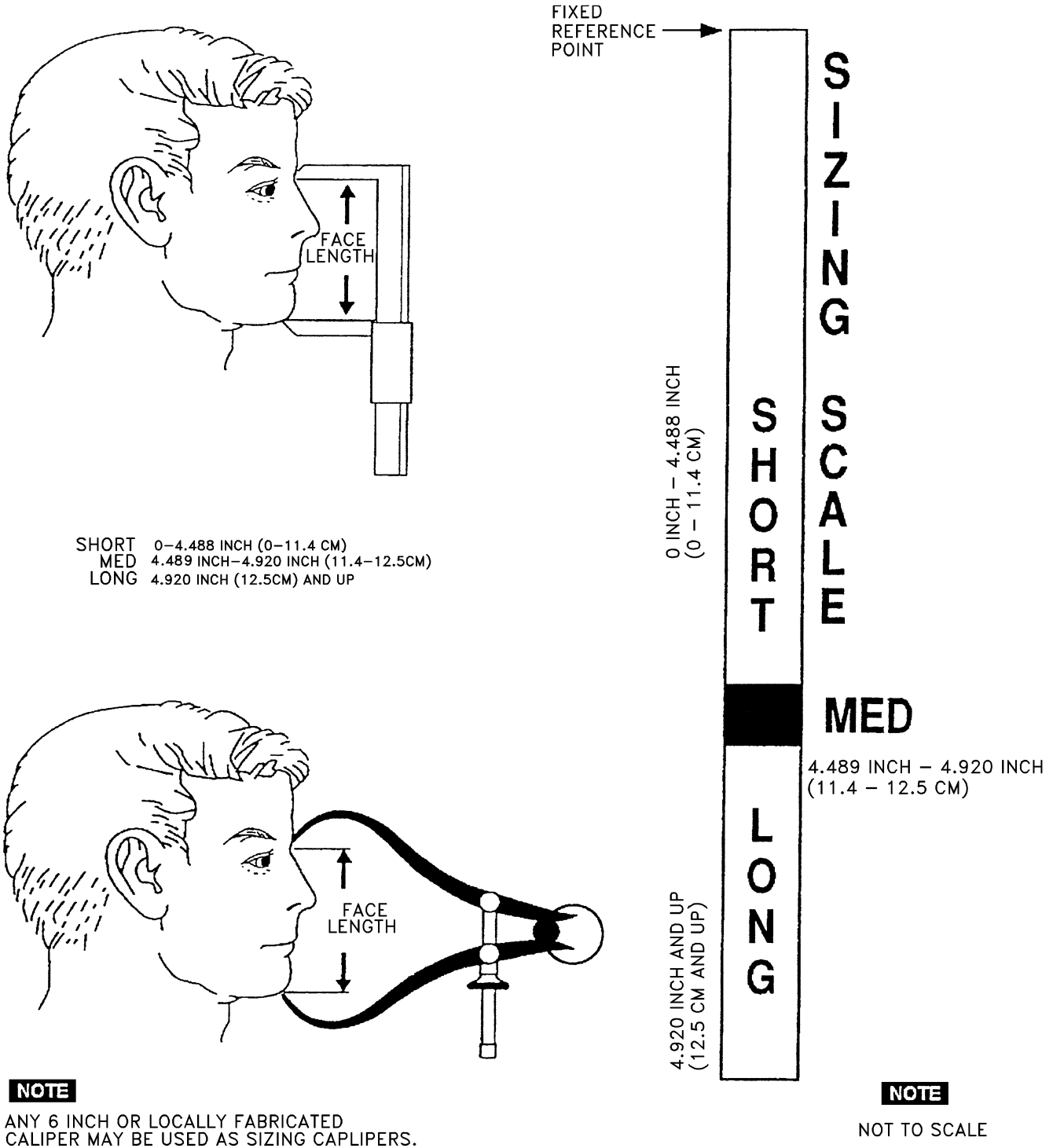

L0003742

Figure 3-2. MCU-2 Series Sizing Scale

3.5 MASK FITTING.

A correctly adjusted mask is necessary for proper fit and to prevent leaks. To adjust the mask, the following procedures should be used:



Failure to follow instructions as prescribed in paragraph 3.5 could result in improper mask fit causing the mask to leak.

NOTE

Make sure the small rubber plug found in the intake hole of some new canisters, and the screw cap protecting the intake valve of new masks, have been removed.

- a. Individuals will remove earrings, contact lenses, hair fasteners (hairclips, pins, etc.) and hairpieces. Hair must hang freely and will be neatly tucked inside Ground Crew Ensemble (GCE) jacket prior to donning mask.
- b. Individuals requiring corrective lenses will don approved combat spectacles/inserts.
- c. Portions of the face that have direct contact with the facepiece must be free of facial hair.
- d. Screw one canister on facepiece.
- e. Loosen straps of head harness. Be sure strap end tabs are approximately 1 inch from buckles.
- f. Remove outsert by pulling down on rubber strap under front voicemitter and lifting out and up.
- g. Reverse head harness by pulling harness over front of mask.
- h. Hold the outlet valve assembly in palm of one hand. Using free hand, push forehead hair aside. Place mask on face forcing chincup very tightly against chin. Pull head harness over head using quick-don tab (Figure 1-1).

NOTE

The facepiece should come well up on the forehead but should not extend over the hairline at any point.

- i. Push mask as high on face as possible. Look down at nose to be sure mask is centered. Hold in this

position with one hand until temple straps are tightened.



Women will remove hair fasteners (hair clips, pins) and let hair hang freely before donning mask. When wearing Ground Crew Ensemble (GCE), hair will be neatly tucked inside jacket. Failure to do so could result in an improper mask fit resulting in illness or death.

- j. Tighten one temple strap (Figure 3-3) with small jerks until mask feels snug on that side. Tighten other temple strap in same manner until both sides feel the same.

NOTE

- Tighten all straps towards rear of head.
 - The straps should not cut into the ears.
- k. Check that headpad is centered at the high point of rear of head. Adjust harness if necessary.
 - l. Using both hands, run a finger under each temple tab front-to back to check for snugness and to remove stray hair from sealing area.
 - m. Grasp a neck strap (Figure 3-3) in each hand and tighten with small jerking motions.

NOTE

The bottom parts of the facepiece should not cut into the throat.

- n. Grasp a forehead strap (Figure 3-3) in each hand and tighten in small jerking motions.

NOTE

Make sure chin remains seated in chincup so the mask will fit properly.

- o. Shake head quickly from side-to-side and up and down. Adjust mask straps as necessary.

NOTE

- The nosecup should not interfere with vision or press painfully on the nose.
- For persons wearing combat spectacles, there should be no interference between the nosecup and the bridge of the spectacles.

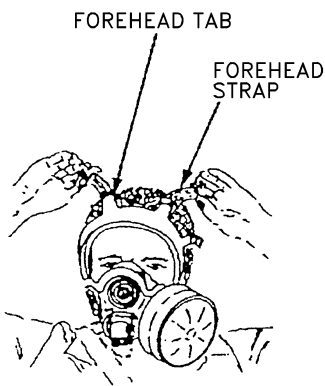
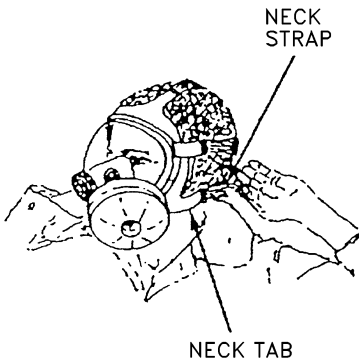
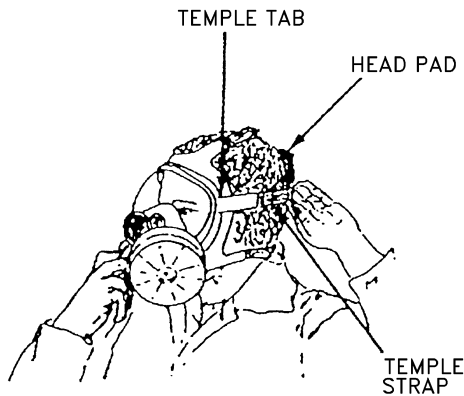

L0003743

Figure 3-3. Adjusting Straps

3.6 DRINK TUBE LEAK CHECK.

- a. Check internal and external drink tubes for a secure fit at outlet valve feed through pipes.
- b. Steady mask and pull canteen coupling out of outlet valve cover.
- c. Grasp outlet valve assembly with thumb at bottom and forefinger at top. Push forefinger toward mouth to get internal drinking tube end between teeth.

WARNING

If resistance is not felt when blowing and sucking into or sucking through the drinking tube, a leak is present and toxic agents may enter the mask.

- d. Test drinking tube assembly for leaks by blowing and sucking into tube. If resistance is not felt, a leak is present. Repair mask (Refer to Chapter 5) or obtain a replacement.
- e. Push coupling firmly back into its socket. The mask may now be checked for leaks around the seal.

3.7 NEGATIVE PRESSURE CHECK.

WARNING

Failure to perform negative pressure check may result in illness or death due to exposure to chemical/biological agents.

- a. Make sure canister is screwed in tight.
- b. Press palm of hand over intake hole of canister. Breathe in lightly until lens deflects. Hold breath for a few seconds. If lens remains deflected, this gives indication of an initial proper fit. Proceed to paragraph 3.9. If lens does not remain deflected, proceed back to paragraph 3.5 and re-accomplish steps.

3.8 ACCOMPLISH QUANTITATIVE FIT TRAINING (QNFT).

Following guidance and procedures set forth in AFMAN 32-4006 and T.O. 14P4-15-11, accomplish QNFT utilizing the Protection Assessment Test System (PATS), M41.

NOTE

Leaks around the edge of the mask are usually caused by bad fit. Most leaks may be found by feeling incoming air on the face or locating with a finger. Make sure the harness head pad is centered at the high point on the rear of head.

3.9 CANISTER CONVERSION OPTION.

The filter canister may be mounted on either the left or right side of the mask as desired. To reverse the positions of the inlet valve assembly/canister, and the side voicemitter, proceed as follows:

- a. Remove canister (if installed).
- b. Gently push center of valve body (Figure 3-6) until it pops through port.
- c. Remove assembly from inside facepiece.
- d. Pull inlet valve body from air deflector post.
- e. With the straight side of carrier shoulder strap D-ring, unscrew and take out side voicemitter retaining ring, voicemitter and gasket (Figure 3-7, views A, B, C, D and E). Discard gasket (if UNSERVICEABLE).
- f. Push inlet valve body in desired port. Make sure inlet valve body is seated in facepiece side port.
- g. Make sure inlet valve disc is seated in the lower slot (narrowest) of the air deflector post.
- h. From inside facepiece, push air deflector assembly into valve body while holding valve body in port. Head of air deflector post must stick through hole in center of valve body. Side edges of air deflector should be between the raised parallel guides on inside of facepiece.
- i. Rotate valve body using tabs to verify correct seating.
- j. Screw canister into facepiece and handtighten.

WARNING

- Make sure side voicemitter is installed with the flange and four pins facing outward (Figure 3-7, view D). Incorrect installation will result in leakage of toxic agents into the mask causing illness or death.
 - Visually inspect voicemitter gasket for cuts, distortion or damage. If any doubt exists regarding its integrity replace with a new serviceable gasket.
- k. Install gasket and voicemitter in remaining port. Screw in voicemitter retaining ring (slots outwards) and tighten with carrier D-ring.
 - l. Perform Negative Pressure Check (paragraph 3.7).

3.10 HOODS W/O NECK CORD, UNDERARM STRAPS OR TEMPLE STRAPS.

A limited number of early production hoods are not equipped with a neck cord, underarm straps or temple straps and cannot be attached to the mask. These type hoods are no longer authorized for use with the MCU-2 Series mask.

3.11 STOWING MASK AND HOOD FOR OPERATIONAL USE.

Attach hood to mask as follows:

- a. Unfold hood and loosen neck cord.
- b. Turn hood inside out.
- c. Spread hood flat, with the face opening up.
- d. Unfasten underarm straps and hood temple straps (Figure 3-4).
- e. Place mask face down on hood and insert the canister through face opening. Adjust mask neck straps so ends are within 1 inch of buckles.
- f. Fasten hood temple straps over mask temple tabs.
- g. Turn hood right side out.
- h. Stretch hood face opening around top and sides of mask lens.
- i. Make sure hood covers top of the outlet valve cover.
- j. If hood is to be worn in a biological or radiological environment with temperatures below 30°F (-1°C) or above 90°F (32°C), stretch lower part of face

T.O. 14P4-15-1

opening over outlet valve portion of the assembly so that the outlet valve cover is outside hood. This procedure is not authorized in a chemical environment.

- k. Raise back of hood up and over face of mask. Reverse head harness over face of mask.
- l. Fold sides of hood so that it crosses over the outlet valve.
- m. Tuck underarm straps into V at outlet valve.
- n. Raise folded hood up to cover the eye lens outsert and fit it snugly under the reversed head harness. The hood material must not obstruct the quick-don tab on the harness.
- o. Stow mask and hood in carrier.

3.12 LONG TERM STORAGE.

Long-term storage is considered any period of time the mask is to be stowed for greater than 30 days. Mask storage configuration will be in accordance with paragraph 3.11

with the following exception: during long term storage the head harness or skull cap is to be left in its normal position with no tension applied to mask or head harness/skullcap. Normal position for the mask is considered to be with head harness/skullcap hanging to the rear of the mask, and not pulled over the front of the eye lens.

3.13 PREPARATION FOR SHIPMENT.

3.14 PRE-PACKING INSPECTION.

Inspect mask and accessories as directed in paragraph 5.2, Inspection and Preventive Maintenance.

3.15 PACKING.

Place mask to be shipped in a container of suitable size and strength to meet shipping requirements and protect mask from items being placed on top that may cause undue stress or damage.

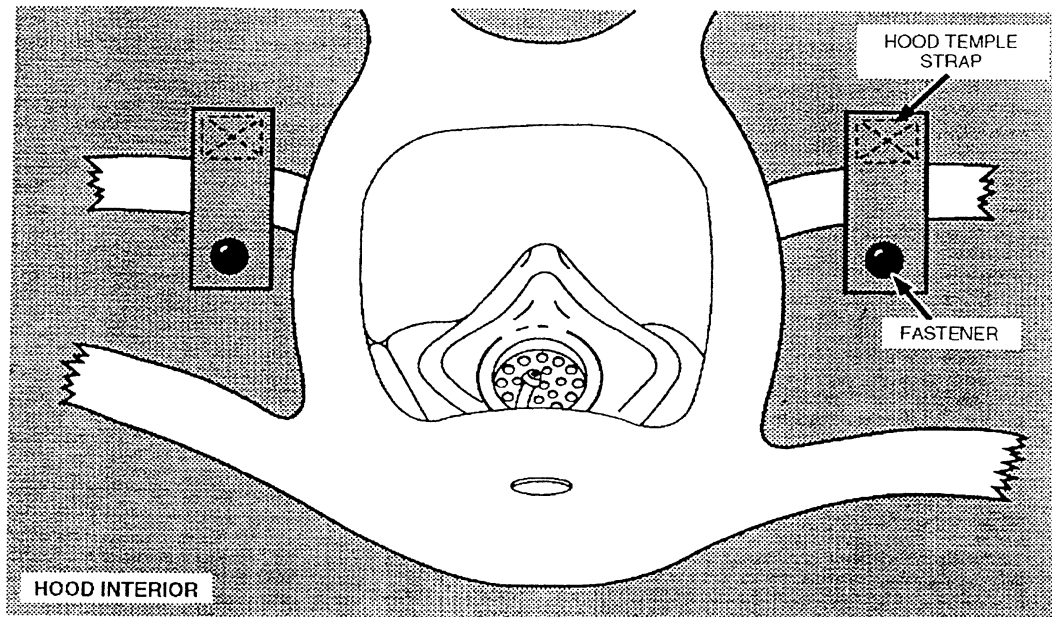

L0003744

Figure 3-4. Attaching Hood to Mask

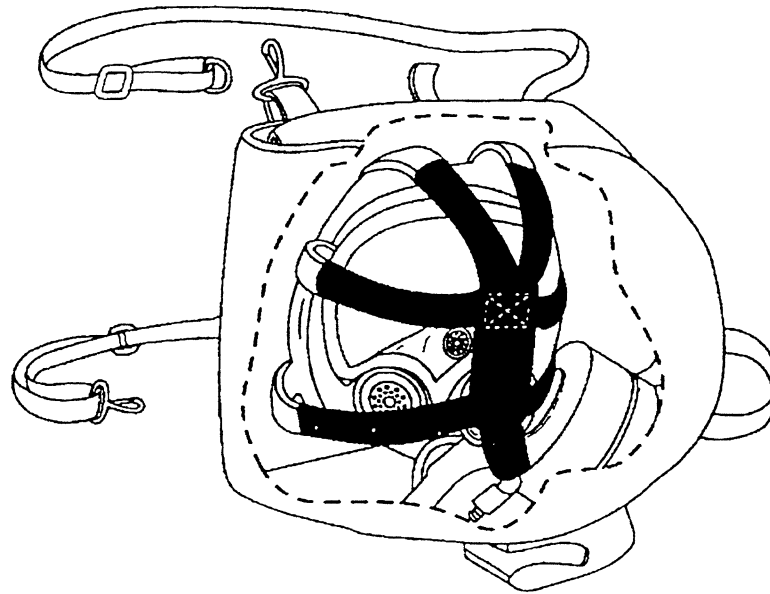

L0003745

Figure 3-5. Mask Stowed in Carrier (Operational)

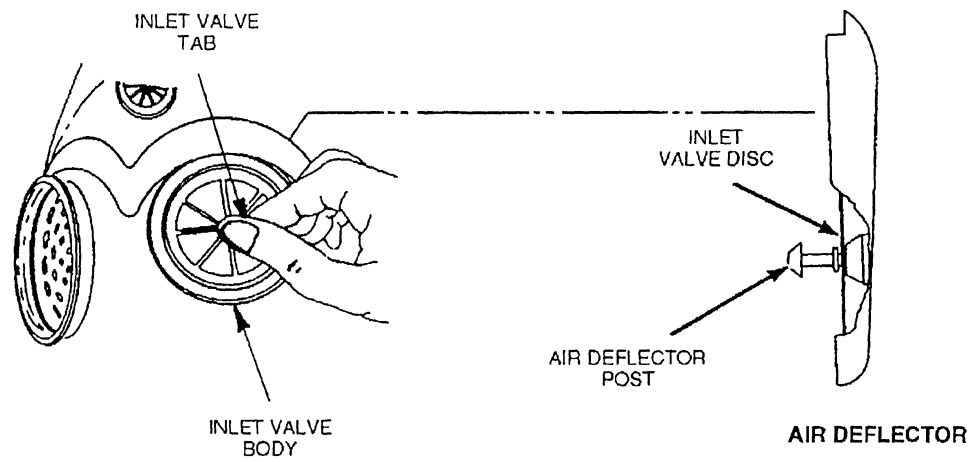

L0003746

Figure 3-6. Inlet Valve Assembly

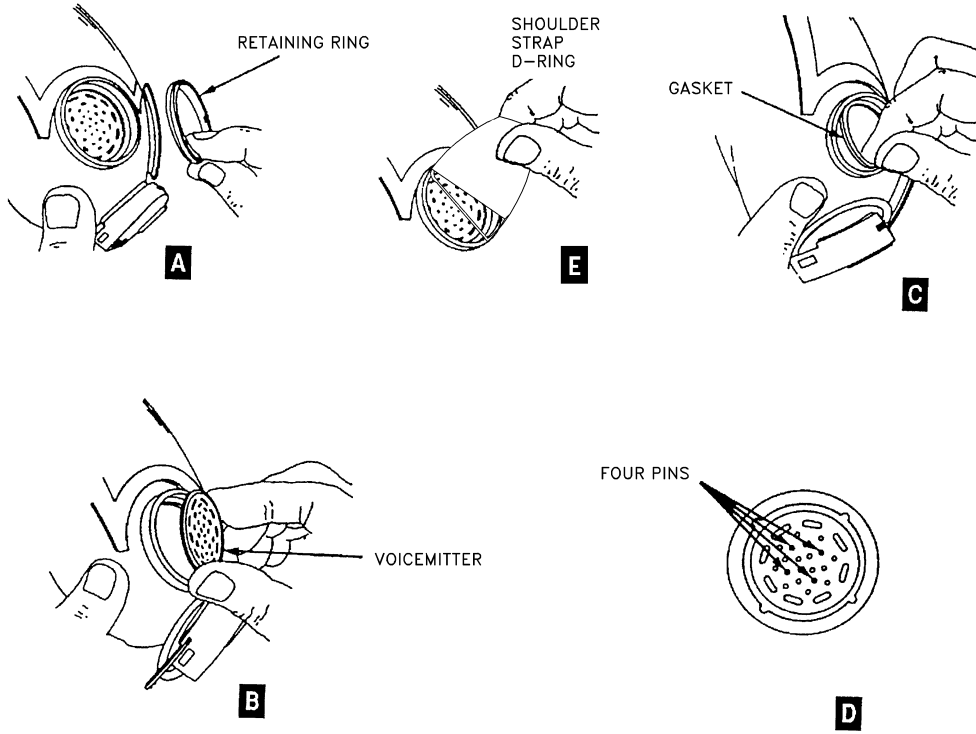

L0003747

Figure 3-7. Side Voicemitter Assembly

CHAPTER 4

OPERATION INSTRUCTIONS

4.1 THEORY OF OPERATION.

(Figure 4-1).



The MCU-2 Series mask is not an authorized respiratory device for industrial chemical use. The canister will not protect against ammonia or carbon monoxide, and the mask is not effective in confined spaces where there is not enough oxygen in the air to support life.

NOTE

Operational masks must be prefitted before stowing it in the carrier. Due to the short time from agent detection to mask donning, the wearer must become an expert in donning the mask and getting an air tight seal in nine seconds with an additional six seconds to adjust the hood when attached. Adjusting the hood will consist of pulling the hood over the head to the shoulders and tightening the neck cord. Attaching the underarm straps is required but will not be considered as part of the fifteen second donning time criteria policy (STANAG 2150).

4.2 INHALATION.

Air enters the mask through the canister which filters out toxic agents before air enters the facepiece. The facepiece provides a gas-tight seal with the face. This allows only filtered air to enter through the inlet valve assembly. The inlet valve assembly consists of a one way valve and an air deflector. The air deflector deflects air across the lens to prevent fogging. The inlet valve assembly also prevents exhaled air from entering the canister. Filtered air, after passing over the lens, is drawn through the nosecup valves. These one-way valves are located in the top portion of the nosecup. The nosecup covers the user's nose and mouth. It is used with the nosecup valves to prevent warm exhaled air from fogging the lens.

4.3 EXHALATION.

Exhaled air, from the nose or mouth, is directed through the outlet valve. This one-way valve lets exhaled air escape from the mask and prevents unfiltered air from entering. Exhaled air then passes through the outlet valve cover. This cover is designed to prevent toxic agents from entering the facepiece assembly while the outlet valve is seating. It also serves the purpose of protecting the outlet valve.

4.4 VOICE COMMUNICATIONS.

Two voicemitters help the user to talk with other personnel. The front voicemitter transmits the user's voice outside the mask when speaking to other personnel. The side voicemitter also transmits the user's voice outside the mask and is useful when using the telephone or other communications devices.

4.5 LEFT-HANDED USE.

This mask has been designed to permit left-handed use. Conversion (refer to 3.9) consists of switching the location of the canister and inlet valve assembly with the side voicemitter. This conversion does not change the theory of operation of the mask.

4.6 DRINKING TUBE.

A flexible drinking tube is provided to let the user drink from a canteen. The external part of this drinking tube has a one-way valve to plug into an M1 canteen cap. Water flowing through the valve passes through a tube in the outlet valve assembly to an internal drinking tube inside the mask. When not in use, the outside end of the drinking tube is stored in a pocket of the outlet valve cover.

4.7 CARRIER.

The carrier protects the mask from damage when not in use.

4.8 OPERATING INSTRUCTIONS.



- With suspected presence of contamination, don your mask immediately. You must put the mask on before you take another breath. Toxic agents may be in the surrounding air.
- You must check the mask for leaks when it is fitted and each time you put it on. A leaky mask will not protect you from toxic agents.
- Do not hold mask by canister. A canister which has unscrewed may allow toxic agents to enter the mask.

4.9 The mask carrier may be worn in a variety of positions (Figure 4-2). The paragraphs that follow illustrate three of these.

NOTE

To eliminate potential glare, the clear plastic window on the outside of the carrier may be covered with a piece of olive drab or subdue tape.

4.10 Shoulder Carry Position:

- a. Hold carrier against left side with carrier flap pile fastener towards body. Pass shoulder strap around back and over right shoulder. Fasten D-ring to hook sewn on top inside corner. Adjust shoulder strap so carrier hangs at waist.
- b. Route waist strap towards back, around waist, and connect strap hook to O-Ring on carrier. Adjust strap for a close secure fit.

4.11 Leg Carry Position (with web belt):

- a. Roll up shoulder strap. Put in shoulder strap pocket.
- b. Hold carrier against left hip with carrier flap pile fastener towards leg. Fasten front hook to web belt. Fasten rear hook (on short wide strap) to web belt.
- c. Route waist strap back, around left leg (a double wrap may be required for smaller leg), and connect

strap hook up O-Ring on carrier. Adjust strap for a close secure fit.

4.12 Leg Carry Position (without web belt):

- a. Hold carrier against left hip with carrier flap pile fastener towards leg. Pass shoulder strap around waist. Fasten D-ring to hook sewn on top inside corner. Adjust strap so that carrier is snug around waist.
- b. Route waist strap back, around left leg (a double wrap may be required for smaller leg), and connect strap hook to O-Ring on carrier. Adjust strap for a close secure fit.

4.13 DONNING PROCEDURES.

Separate donning procedures are included in the following paragraphs for:

- a. Masks with attached hoods.
- b. Mask only.

Follow the applicable procedure for your type mask/hood.

NOTE

- These procedures presume the following:
 - Eyeglasses and/or contact lenses have been removed.
 - Combat spectacles/inserts in place or donned.
 - The mask is in the carrier.
 - Mask is serviceable and properly fitted.
 - An outsert is attached to the mask.
 - The head harness is inverted over the front of the mask and the temple and forehead straps are preadjusted for donning.
- c. Mask with Joint Service Lightweight Integrated Suit Technology (JSLIST) Overgarment. Follow procedures in T.O. 14P3-1-141.

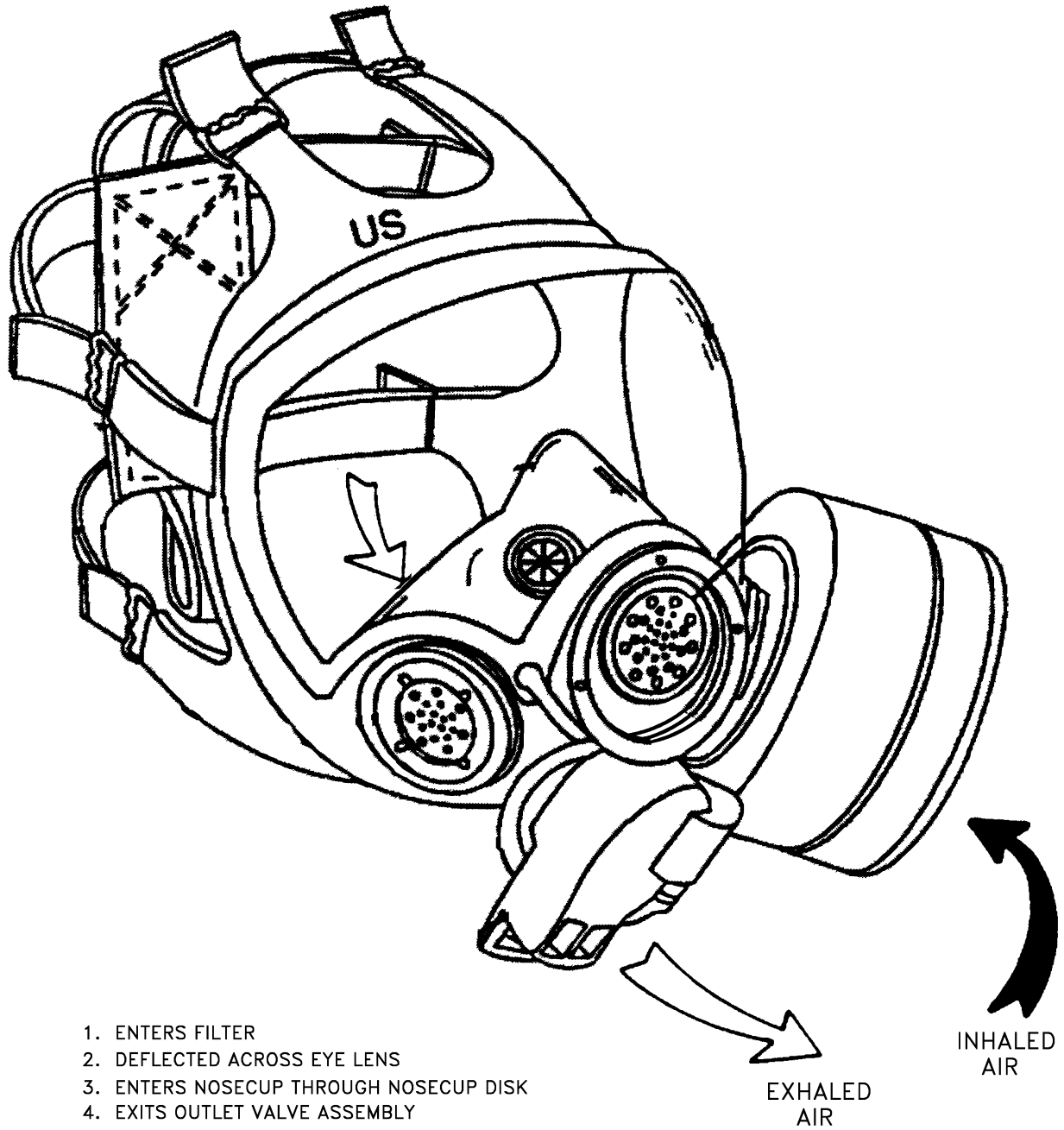

L0003748

Figure 4-1. MCU-2 Series Air Flow



SHOULDER
CARRY POSITION

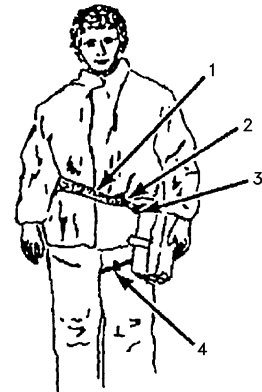

LEG CARRY
POSITION
(WITHOUT WEB BELT)

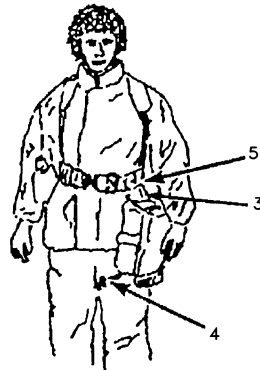

LEG CARRY
POSITION
(WITH WEB BELT)

1. SHOULDER STRAP
2. D-RING
3. FRONT HOOK
4. WAIST STRAP
5. REAR HOOK
6. SHOULDER STRAP POCKET
7. WAIST STRAP HOOK
8. PILE FASTNER
9. ACCESSORY POCKET
10. CARRIER FLAP PULL TAB
11. INSIDE TOP POCKET
12. LARGE INSIDE POCKET
(FLUSH WITH SIDE SHOWN)
13. SMALL D-RING
14. O-RING
15. REAR WEB BELT STRAP

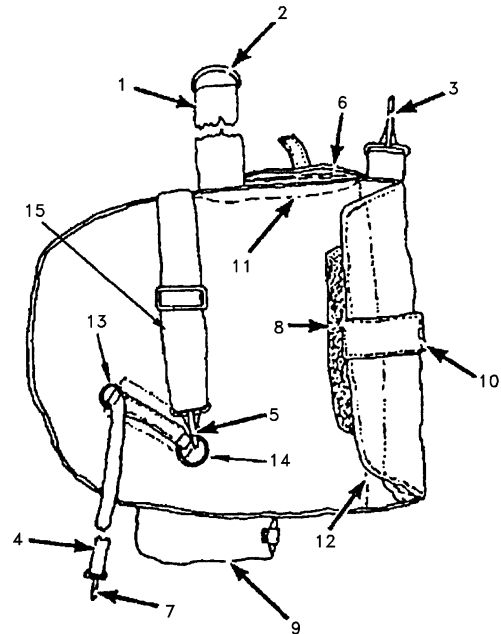

L0003749

Figure 4-2. Mask Carrier Wear

4.14 DONNING PROCEDURES FOR MASKS WITH ATTACHED HOODS.

Don the mask in the following steps (Figure 4-3).

WARNING

- With suspected presence of contamination, don your mask immediately. You must put the mask on before you take another breath. Toxic agents may be in the surrounding air.
 - Individuals will remove earrings, contact lenses, hair fasteners (hairclips, pins, etc.,) and hairpieces. Hair must hang freely and will be neatly tucked inside Ground Crew Ensemble jacket prior to donning mask.
- a. STOP BREATHING.
 - b. Close eyes tightly.
 - c. Remove headgear.

CAUTION

Never remove the mask from the carrier by pulling on the outlet valve cover. The cover may tear.

- d. With left hand, grasp carrier flap tab. With a quick firm motion pull outward to open the carrier. Reach into carrier with right hand. Grasp mask and withdraw the mask and hood from carrier.
- e. Hold outlet valve assembly in palm of one hand. Using free hand, push forehead hair aside. Place mask on face, forcing chin cup tightly against chin. Pull head harness over head using the quick-don tab (Figure 1-1).
- f. Grasp a neck strap in each hand and tighten with small jerking motions.
- g. Cover opening at bottom of outlet valve with palm of hand before expelling air that has been held in lungs.

- h. Press palm of one hand over the canister opening. Inhale to determine whether an airtight seal of mask against face has been obtained. If mask doesn't collapse, check for hair or other material between mask seal and the face. Adjust straps if necessary and recheck.
- i. Open eyes and RESUME NORMAL BREATHING.
- j. Pull back of hood over head so that hood covers head. Drape cape over shoulders. Make sure that the cape is under neck cord.
- k. Use neck cord fastener to tighten neck cord until hood is held snugly around neck.
- l. Pass straps under arms. Place neck cord over rug of hook fastener. Take hook of the strap and fasten to the rug with the neck cord between the ends of the fastener.
- m. Replace headgear and close carrier.

NOTE

- During a radiological or biological environment, at temperatures below 30°F. (-1°C) and above 90°F (32°C), the hood can be under the outlet valve cover.
- When the hood is positioned over the outlet valve cover (Figure 4-3) the hood fills slightly with air. This inside pressure provides additional protection to the head, neck, and respiratory areas of the user. The effects of a bad fit, careless donning, or beard growth can be minimized by placing the hood over the outlet valve cover. This also gives more protection under windy conditions.
- During a chemical environment, mask utilizing the attached hood will be positioned over the outlet valve cover at all times.

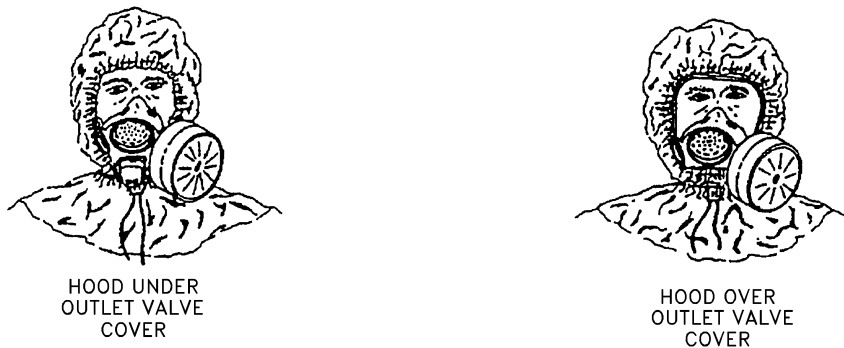

L0003750

Figure 4-3. Hood Donned

4.15 DONNING PROCEDURES FOR MASK ONLY.

Don the mask in the following steps:



- With suspected presence of contamination, don your mask immediately. You must put the mask on before you take another breath. Toxic agents may be in the surrounding air.
- You must check the mask for leaks when it is fitted and each time you put it on. A leaky mask will not protect you from toxic agents.
- Do not hold mask by canister. A canister which has unscrewed may allow toxic agents to enter the mask.

- a. STOP BREATHING.
- b. Close eyes tightly.
- c. Remove headgear.



Never remove the mask from the carrier by pulling on the outlet valve cover.

- d. With left hand, grasp carrier flap tab. With a quick firm motion pull outward to open carrier. Reach into carrier with right hand. Grasp mask by front

portion of facepiece in area of voicemitter-outlet valve assembly. Withdraw mask from carrier.

- e. Hold outlet valve assembly in palm of one hand. Using free hand, push forehead hair aside. Place mask on face, forcing chincup tightly against chin. Pull head harness over head using quick-don tab (Figure 1-1).

NOTE

Both hands may be used.

- f. Grasp a neck strap in each hand and tighten with small jerking motions.

NOTE

Make sure chin remains seated in chincup so the mask will fit properly.

- g. Cover opening at bottom of outlet valve with palm of hand before expelling air that has been held in lungs.
- h. Press palm of one hand over canister opening. Inhale to determine whether an airtight seal of mask against face has been obtained. If mask doesn't collapse, check for hair or other material between mask seal and the face. Adjust straps if necessary and recheck.
- i. Open eyes. Resume normal breathing.
- j. Replace headgear and close carrier.

4.16 DOFFING PROCEDURES.

Separate doffing procedures are included in the following paragraphs for:

- a. Masks with attached hoods (Hoods having neck cord, underarm straps and temple tab straps).
- b. Mask only.
- c. Mask with Joint Service Lightweight Integrated Suit Technology (JSLIST) Overgarment. Follow procedures in T.O. 14P3-1-141. Follow the applicable procedure for your type.

WARNING

Doffing procedures for contaminated equipment is covered in AFMAN 32-4005.

4.17 DOFFING PROCEDURES FOR MASKS WITH ATTACHED HOODS.

- a. Unfasten underarm straps.
- b. Loosen neck cord by sliding fastener to end of cord.
- c. Pull back of cape forward over head and leave hood suspended from front of mask.

WARNING

Failure to loosen the bottom straps on the mask prior to removing the mask will place excessive and undue stress on the outlet valve assembly. This stress on the outlet valve assembly will contribute to disbonding of the mask.

- d. Loosen mask neck straps. Grasp mask by outlet valve assembly and remove by pulling down, outward, and up.
- e. Reverse head harness over mask facepiece.
- f. Shake or wipe any moisture or frost accumulations from inside of hood and mask.
- g. Fold in accordance with paragraphs 3.11.1., m., and n.

- h. Stow mask and hood in carrier.

4.18 DOFFING PROCEDURES FOR MASK ONLY.

WARNING

Failure to loosen the bottom straps on the mask prior to removing the mask will place excessive and undue stress on the outlet valve assembly. This stress on the outlet valve assembly will contribute to disbonding of the mask.

- a. Loosen mask neck straps by rotating buckles forward. Grasp mask by outlet valve body and remove by pulling down, outward, and up.
- b. Reverse head harness over mask facepiece lens and shake or wipe any moisture from inside mask.
- c. Stow mask in carrier.

- 4.19 Using the mask drinking tube (Figure 4-4) proceed as follows:

WARNING

Decontaminate canteen cap and drinking tube coupling prior to use in a suspected contaminated environment.

NOTE

The outlet valve cover must be outside hood to obtain access to the drinking tube.

- a. Steady mask to avoid breaking seal and pull drinking tube coupling out of outlet valve cover.
- b. Take out canteen and flip open cover on M-1 canteen cap.
- c. Push coupling into canteen cap so that pin enters coupling.
- d. Grasp outlet valve assembly with thumb at bottom and forefinger at top. Push forefinger toward mouth to get internal drinking tube end between teeth.

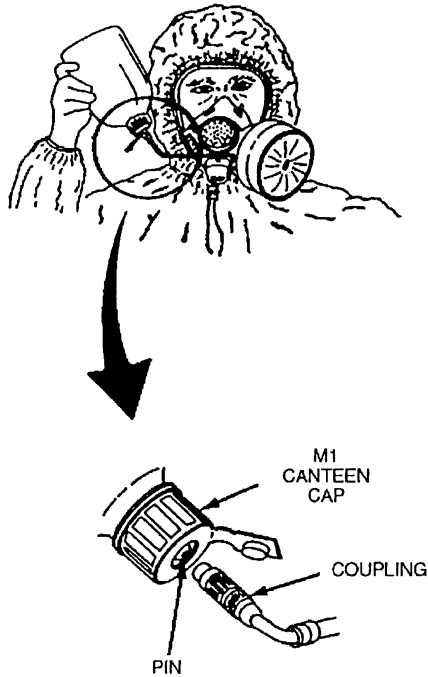

L0003751

Figure 4-4. Drinking Tube Use

NOTE

Water may leak into mask if mouth is taken off drinking tube.

- e. Raise canteen and drink. After several swallows, stop sucking and allow air in mask to enter canteen. This will prevent canteen from collapsing. Repeat drinking procedure as required.
- f. Disconnect drinking tube by blowing into drinking tube while twisting and pulling coupling out of canteen.
- g. Push coupling firmly back into its socket.

- h. Flip down cover on canteen cap and stow canteen.
- i. Return hood to original position (if required).

4.20 To use the mask waterproofing bag (Figure 4-5) proceed as follows:

WARNING

Do not store food in the waterproofing bag. Possible toxic effects may result.

CAUTION

Do not store your mask in the waterproofing bag for more than 24 hours. Moisture and off-gassing buildup in the bag may damage the canister.

- a. Pull open carrier flap, and pocket flap. Take out waterproofing bag envelope.
- b. Open waterproofing bag envelope. Take out waterproofing bag and envelope containing rubber bands (as applicable).
- c. Put mask in bag with front voicemitter toward open end of bag.
- d. Gather open end of bag near the mask. Squeeze bag from this point toward open end to force out air.
 - (1) If using bag equipped with rubber bands for securing, twist open end tightly. Fold twisted part back on itself and wrap supplied rubber band around folded end of bag as many times as possible (Figure 4-5).
 - (2) If using the (newer) ziplock water proofing bag, fold the bag (between the mask and the ziplock) and hold to keep air out. Align the ziplock, and close by applying enough pressure to secure.

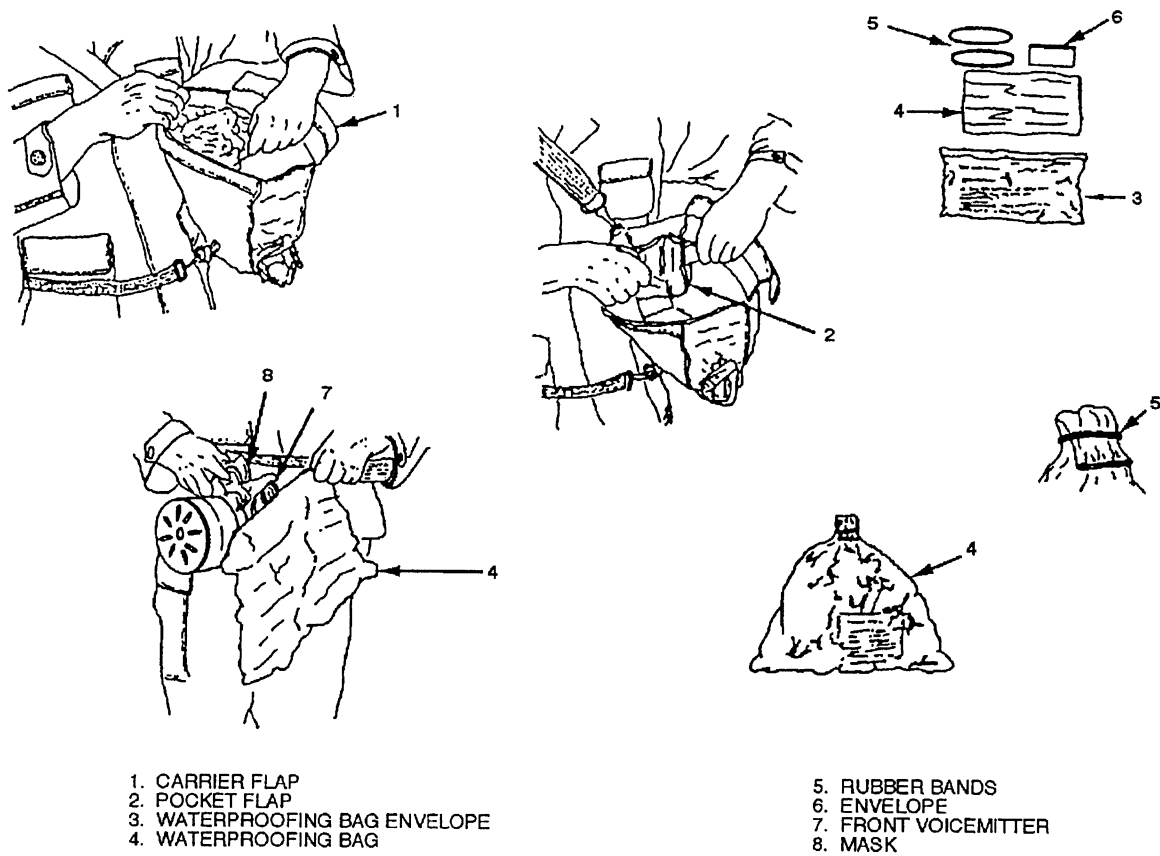

L0003752

Figure 4-5. Waterproofing Bag Use

- e. Put bag in carrier with fold toward front of carrier.
 - f. Close carrier flap.
- 4.21 When use of the waterproofing bag is no longer required proceed as follows:
- a. Pull open carrier flap and pull out bag.
 - b. Remove mask from bag.
 - c. Fold bag neatly. Place bag and rubber band(s) (as applicable) in waterproofing bag envelope.
 - d. Put waterproofing bag envelope in carrier pocket and close flap.

- 4.22 Cold Weather Operation. General instructions that must be followed in cold weather include the following:
- a. Before entering a warm area from freezing temperatures, remove frost and snow from mask.
 - b. Dry mask with a clean cloth, in a warm indoor area. Carefully dry outlet and nosecup valves.

- 4.23 Follow the usual procedures when donning or wearing the mask in cold weather, but keep in mind the following points:
- a. Do not breathe out forcefully or the eyelens will steam up.

T.O. 14P4-15-1

- b. If outlet valve disc sticks to valve seat, place finger against the center of the outlet valve cover. Depress cover inward to make contact with disc. Move finger in a circular motion while exhaling slowly. If this does not free disc, pull up the outlet valve cover. Massage disc lightly with one finger while exhaling slowly (Figure 4-6). Massage until valve disc functions properly.

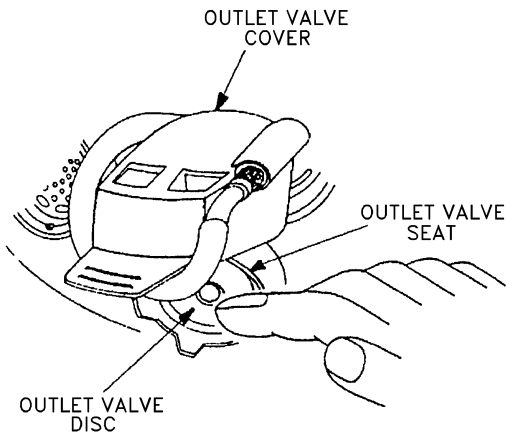

L0003753

Figure 4-6. Freeing Stuck Outlet Valve Disc

NOTE

Massage valve disc while exhaling only. This will help to free the stuck outlet valve disc.

WARNING

If you become overheated in cold weather, when possible do not remove your mask outdoors until your head cools and any sweat has dried. Frostbite may result if the mask is removed while your face is still wet.

4.24 To remove mask in cold weather proceed as follows:

- a. Brush any ice or snow from mask before taking it off.

- b. After unmasking, shake ice buildup from mask.
 - c. Stow mask in carrier.
- 4.25 Storage of Mask and Components.

CAUTION

Keep the carrier free of grit and other dirt that might scratch the lens or clog the valves.

- a. Stow waterproofing bag, detector paper and DD Form 1574 in large inside pocket at front of carrier (Figure 4-7).
- b. Install outsert before stowing mask.
- c. Put second outsert (it furnished/required) in outsert bag and place over outside of first outsert and hood, if installed.
- d. Stow hood attached to mask inside carrier.

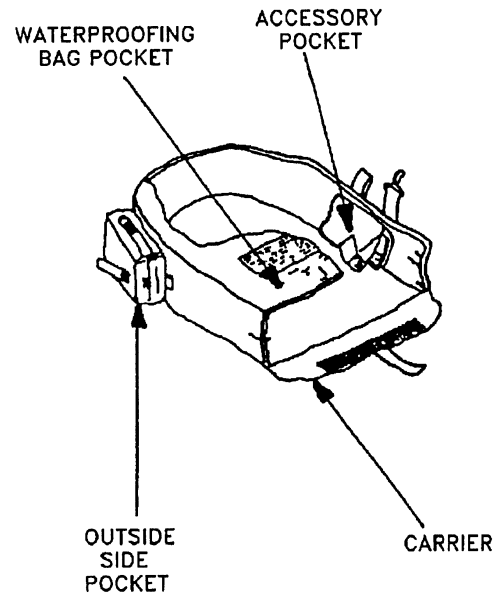

L0003754

Figure 4-7. Carrier Stowing Pockets

CAUTION

- Check that the mask is dry, free of oil and solvents before stowing. Oil or solvents will damage the mask.
 - Do not force the mask into carrier. Mask may be deformed and damaged if forced into carrier.
- e. Stow mask in carrier. (Figure 3-5.)

CAUTION

- Do not store other items on top of the mask or place unauthorized items in the carrier. Damage to the mask may result.
 - Do not store masks in temperatures exceeding +125°F or below -32°F. Excessive temperatures will accelerate material deterioration.
 - Dampness will reduce the life of the canister. Be sure the mask is stored in a dry place.
 - Do not store mask in direct sunlight, or in hot stuffy areas. Damage to the mask will result.
- f. Place carrier in a cool, dry place.

4.26 LIMITATIONS.

- a. The chemical-biological filter canister provided with this mask does not provide protection against ammonia or carbon monoxide fumes.
- b. This mask is not an authorized respiratory device for use during industrial chemical spills, and may not provide protection.

- c. This mask is not effective in confined spaces where there is not enough oxygen in the air you breathe to support life.

4.27 DECONTAMINATION.**WARNING**

If you suspect contact with chemical agent, expediate decontamination of the mask must be accomplished as soon as reasonable possible. Thorough decontamination of the mask and components will be accomplished in accordance with AFMAN 32-4005.

- a. In the field, to limit the amount of chemical agent absorbed into the rubber components of the mask, the mask and hood should be decontaminated as soon as practical after contamination occurs. Decontaminate with M258A1 decontamination kit (Refer to T.O. 11D1-1-111), M291 decontamination kit (Refer to T.O. 11D1-1-131), M295 decontamination kit (Refer to TM 3-4230-235-10), or 5% sodium hypochlorite (household bleach).

WARNING

When in a contaminated environment, pressure shall be applied to the front voicemitter (using two fingers) prior to removing the hood to prevent mask seal from being broken.

- b. In a Contamination Control Area (CCA), decontamination shall be accomplished in accordance with AFMAN 32-4005. Replace hood second skin and outsert when mask is serviced in a CCA.

CHAPTER 5 MAINTENANCE INSTRUCTIONS

5.1 OPERATIONAL CHECKOUT.

NOTE

Masks that have never been issued and are still packaged in unopened original container, do not require an inspection.

Once the MCU-2 Series mask is issued, all maintenance becomes the responsibility of the user. This chapter details procedures for use during maintenance.

5.2 INSPECTION AND PREVENTIVE MAINTENANCE.

- a. This chapter contains the procedures and instructions necessary to perform preventive maintenance checks and services. Table 5-1 provides a list of items to be checked, inspection procedures, and a corrective action or a referral to the Repair and Replacement chapter of this manual. Refer to Figure 5-1 while using this table. Numbers in parentheses () in Table 5-1, refer to the similar numbered items on Figure 5-1 (3 sheets).
- b. Masks will be cleaned and inspected by the individual:
 - (1) Upon issue and every six months after initial issue date during peacetime.
 - (2) Prior to deployment and every seven days during contingency operations.

- (3) Before long term storage (30 days or more)
 - (4) Prior to turn-in to supply.
 - (5) After completion of each training contingency/exercise.
- c. Mask in bulk storage prior to issue will be maintained and inspected as follows:
 - (1) Mask in original manufacture packaging do not require cleaning or inspection.
 - (2) Mask that have been removed from original manufacture packaging will be cleaned and inspected every six months by the possessing unit.
 - d. These inspections shall be documented on a DD Form 1574 or Data Automated System (DAS). The inspection document shall contain at least the following information:
 - (1) Federal stock number of the mask, type, and size. Mask lot number, functional address of inspecting activity, signature of inspector, date inspected, and date next inspection is due.
 - (2) Inspection document can be used to annotate recurring inspections.
 - (3) When a serviceable C₂ series canister is installed, date installed and canister lot number will be annotated in remarks section of DD Form 1574.

Table 5-1. Inspection and Preventive Maintenance Checks

ITEM	INSPECT FOR	CORRECTIVE ACTION
	NOTE	
Facepiece (1)	<ul style="list-style-type: none"> •Take off outsert before inspecting mask. •All personnel must clean mask in accordance with paragraph 5.5 (CLEANING) before inspection of mask. Cracks, tears, or deterioration and separation between silicone, rubber, and the metal parts.	Condemn Mask.
Faceseal (Not Shown) (2)	Cracks or tears. Run finger over seal to inspect for nicks or surface irregularities. Faceseal must be soft, smooth, and pliable.	Condemn Mask.
Forehead, Temple, and Neck Tabs (3)	Nicks or rips, along edges, or where buckles connect. Run a finger around edges to check for discrepancies.	Condemn Mask.

Table 5-1. Inspection and Preventive Maintenance Checks - Continued

ITEM	INSPECT FOR	CORRECTIVE ACTION
Buckles (4)	Bends, cracks or looseness where molded into the facepiece tabs. Pull on head harness straps. Make sure the buckles hold the strap tight.	Condemn Mask.
Head Harness (5)	Tears, surface dirt, or mildew. Pull straps to make sure they have not lost their elasticity.	Replace if straps are torn, broken, or have lost their elasticity. Refer to paragraph 5.8. Clean off surface dirt or mildew with a stiff bristle brush.
Skull Cap (6)	Same as for item 5.	Same as for item 5.
Side Voicemitter Retaining Ring (7)	Corrosion or looseness.	Replace if corroded. Tighten if loose. Refer to paragraph 5.9.
Side Voicemitter (8)	Dents, punctures, or cracks. The four pins in the center face toward the outside of mask.	Replace if dented, punctured, or cracked. Remove and correctly reinstall if four pins are not facing outwards.
Side Voicemitter Gasket (9)	Cracks and cuts.	Install a new side voicemitter gasket, if UNSERVICEABLE, (e.g. cut, distorted or damaged). Refer to paragraph 5.9.a.
WARNING		
Do not attempt in any way to loosen front voicemitter ring during check for tightness.		
Front Voicemitter Retaining Ring (10)	Tightness using the tips of two fingers on the flat part of the ring (See Figure 5-11).	Repair mask in accordance with paragraph 5.17.
Front Voicemitter (11)	Punctures or cracks. (Damaged microphone connector assembly MCU-2A/P).	Repair mask in accordance with paragraph 5.17.
Outlet Valve Cover (12)	Cracks, rips and general cleanliness inside and out.	Replace if cracked, ripped or if it will not seat firmly on outlet valve body. Refer to paragraph 5.10. Wipe away any dirt or moisture on cover with a soft, dry, clean cloth.

Table 5-1. Inspection and Preventive Maintenance Checks - Continued

ITEM	INSPECT FOR	CORRECTIVE ACTION
Outlet Valve Disc and Valve Disc Body (13)	Curls, nicks, rips, dirt or moisture. Turn disc to make sure it is not stuck to valve seat. Make sure outlet valve disc with supportive screen has been installed. Push cover back on outlet valve. Make sure cover is seated firmly.	Replace if curled, nicked, ripped, cannot be cleaned, or will not seat properly. Replace outlet valve disc with supportive screen, if required. Refer to paragraph 5.11. Wipe away any dirt or moisture with a soft, dry, clean cloth.
Nosecup (14)	Lift nose cup from around flange of the outlet valve assembly. Check for disbonding of silicone facepiece to metal outlet valve assembly. Cracks or cuts, and that it is seated in outlet valve flange and securely held around the front voicemitter.	Condemn mask if disbonding has accrued. Condemn Mask if the nosecup is cracked, cut or loose at the voicemitter. If nosecup is not sealed around the outlet valve flange, push the nosecup back over the flange.
Valve Disc (15)	Inspect for proper installation of valve seat or separation from the nosecup. Make sure valve discs are not cut or torn. Turn the disc with the tip of finger to make sure disc are not stuck on valve seats.	If nosecup seats are improperly installed, refer to paragraph 5.16. Replace valve discs that are curled, or torn. Refer to paragraph 5.13.
External Drinking Tube (16)	Cracked, cut or deteriorated rubber. Dented or cracked coupling. Loose on feed through pipe or at metal coupling. Check for stuck valve by performing Drink tube Leak Check in accordance with paragraph 3.6.	Replace in accordance with paragraph 5.14, Figure 5-7.
Internal Drinking Tube (17)	Cracks, cuts, and to see if it is loose on the feed-through pipe.	Replace if cracked, cut or loose. Refer to paragraph 5.15.
Drink Tube Assembly	Perform drink tube leak test in accordance with paragraph 3.6.	Replace if required.
Inlet Valve Disc (18)	Curls or tears. Turn disc to make sure it is not stuck to valve seat. Make sure disc is properly installed on Air Deflector Post.	Replace if curled or torn. Refer to paragraph 5.12. Install valve disc behind valve disc retaining ring. Refer to paragraph 5.12.b., Figure 5-6.
Lens (19)	Punctured lens. Stains or scratches that prevents normal vision. Any separation between the mask lens and facepiece.	Condemn Mask.

Table 5-1. Inspection and Preventive Maintenance Checks - Continued

ITEM	INSPECT FOR	CORRECTIVE ACTION
Canister (20)	Cracks, dents, or holes around the seams, dirt clogging the air intake and for damaged threads. Any signs of loose particles in filter when shaken.	Replace if cracked or dented on a seam, dented deeper than 1/4 inch, if it has holes, threads are damaged, or air intake is clogged with dirt. Refer to T.O. 14P4-1-151. Replace filter if signs of loose particles are present.
Protective Hood (21)	More than 2 pinholes in any one panel. Rips, tears, or if rubber coating is sticky or scuffed off.	Replace Hood.
Carrier (22)	Cleanliness, damage, excessive wear, missing straps or fasteners.	Repair if possible or replace.
Waterproofing Bag (23)	Damage.	Replace if required.
Outsert (24)	Stains or scratches that prevents normal vision. Cracks. Missing clips or rubber straps.	Replace the rubber strap if broken or missing. Refer to paragraph 5.19. Replace outsert if required.
Front Voicemitter/Micmitter Assembly (25)	Broken, missing, damaged, loose, corroded, dirty, etc.	Repair mask in accordance with paragraph 5.17.
Body, Inlet Valve (26)	Cracks, tears or deterioration, surface irregularities and dirt.	Clean if dirty, replace if worn or cracked.

5.3 REPAIR.

All maintenance is done by the replacement of defective parts or in accordance with Table 5-1, Corrective actions column.

5.4 DISASSEMBLY.

What limited disassembly is required by the MCU-2 Series mask is addressed in the Repair or Replacement chapter of this manual (refer to paragraph 5.7).

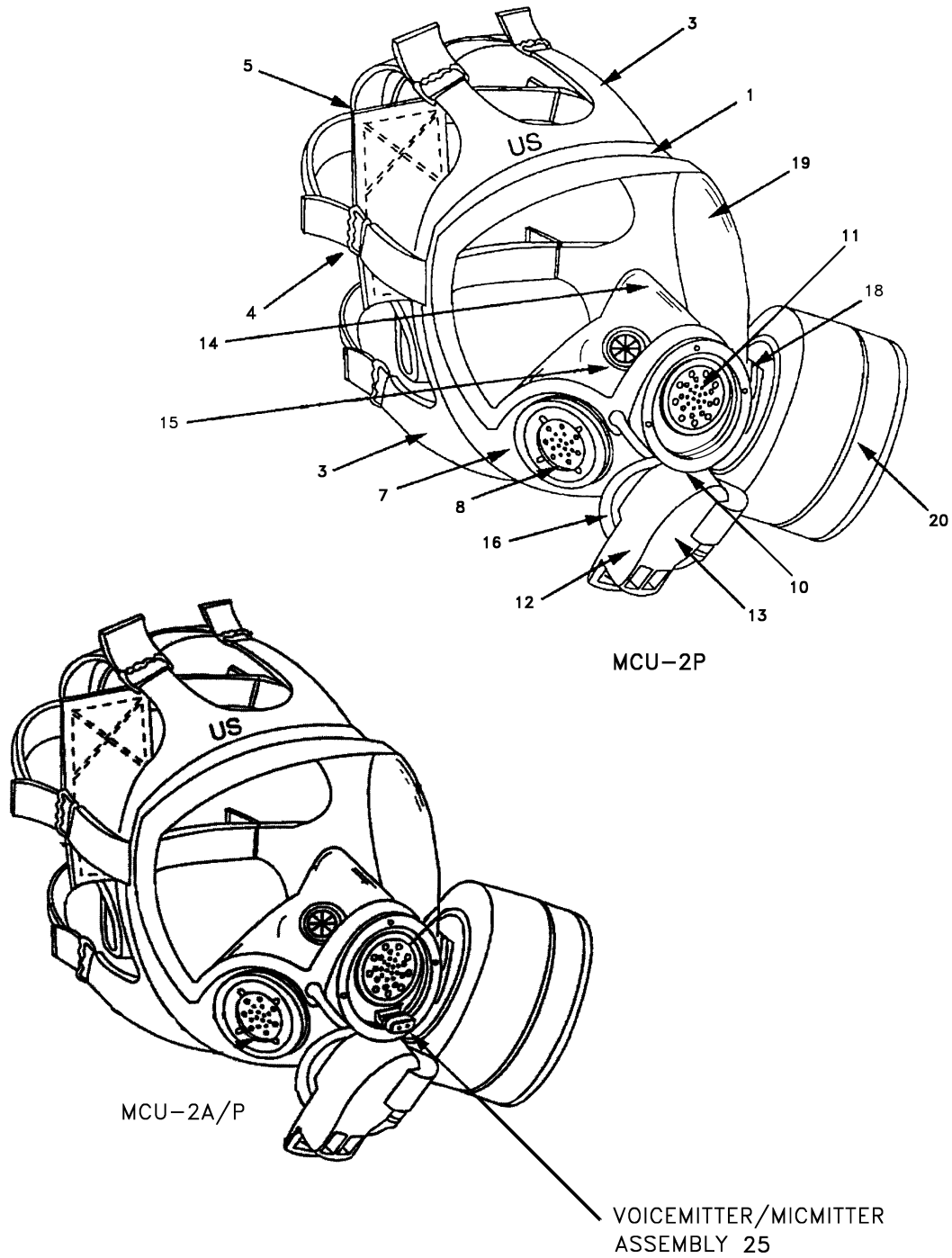
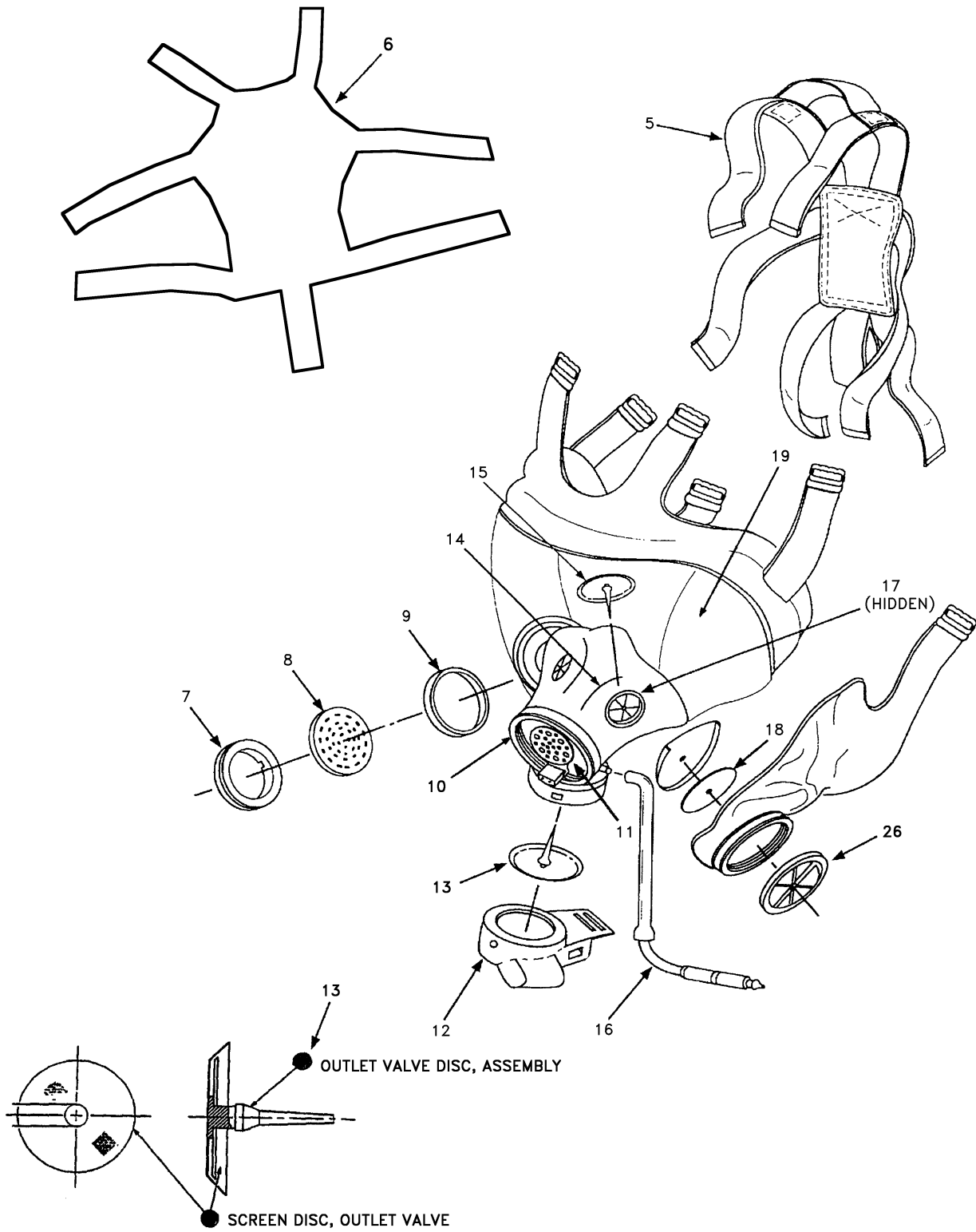

Figure 5-1. MCU-2P and MCU-2A/P Mask Inspection (Sheet 1 of 3)

L0004079



L0004080

Figure 5-1. MCU-2P and MCU-2A/P Mask Inspection (Sheet 2)

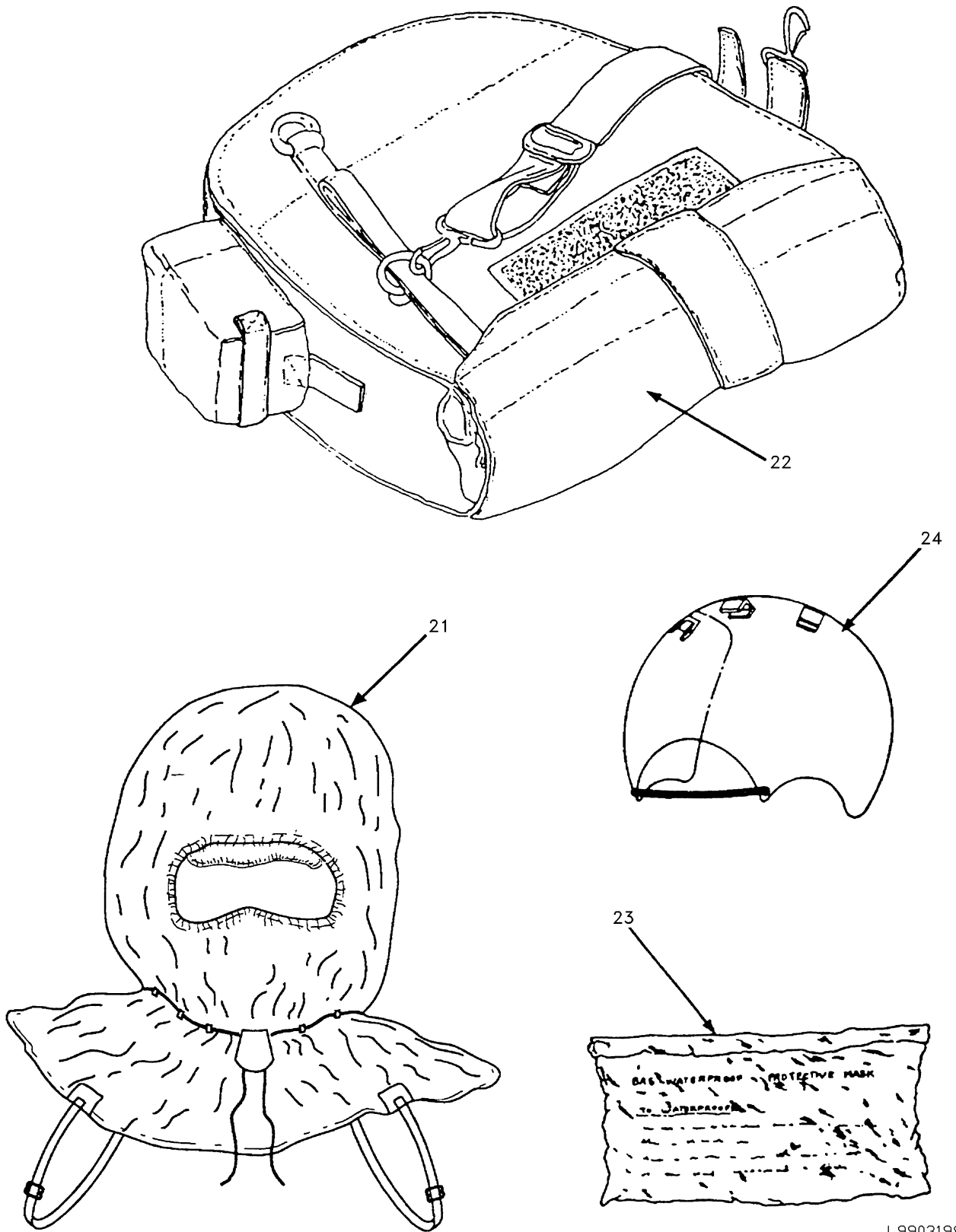

L9903198

Figure 5-1. MCU-2P and MCU-2A/P Mask Inspection (Sheet 3)

5.5 CLEANING AND DISINFECTING MASK.

The MCU-2 Series mask, hood and outserts may be cleaned and disinfected using the following procedures.

- a. Preparation. In order to make sure masks are properly cleaned and disinfected the following preparation procedures must be followed:
 - (1) Remove filter, outsert, hood, outlet valve cover and head harness/skullcap.

WARNING

Removing any screws other than indicated in Figure 5-9 renders mask unserviceable.

CAUTION

Loosen set screws only, do not remove.

- (2) If microphone is installed, refer to paragraph 5.18 5.15.b. and Figure 5-9, reverse the installation procedures to remove microphone.

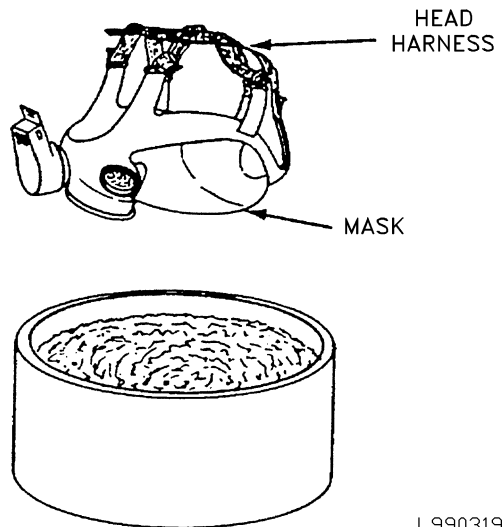
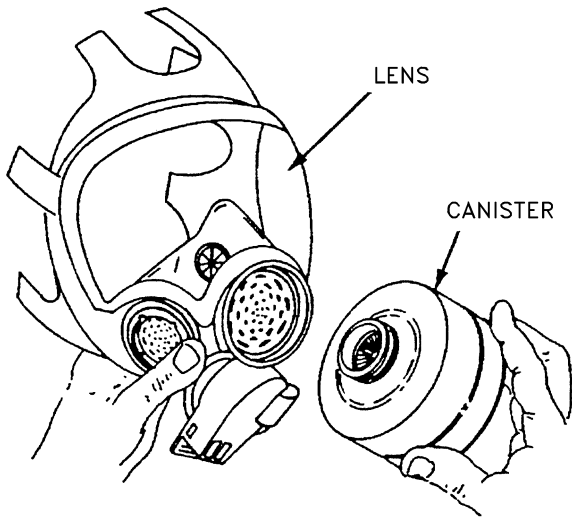

L9903199

Figure 5-2. Cleaning

- b. Cleaning. Cleaning can be accomplished as often as necessary, but as a minimum in accordance with paragraph 5.2.b.(1) through 5.2.b.(5).

CAUTION

- Alcohol based towelettes (or equivalent) may be used for expedient disinfectant of the mask (with the exception of the lens) using a non-scrubbing motion. Take care not to remove/damage lot number on neck tab.
- Do not let the canister get wet.
- Do not place mask in water with temperatures exceeding 110°F.
- Do not dry-wipe lens.

NOTE

To clean the mask use warm potable water (NMT 110°F) and a mild liquid detergent that does not contain Lanolin, oils, perfumes or abrasives.

- (1) Immerse mask and components (outserts, outlet valve cover, and hood) in mild liquid detergent and warm potable water solution. Agitate around in solution.
 - (2) Lift nosecup up and remove from around flange of outlet valve assembly to facilitate and thorough cleaning between nosecup and facepiece.
 - (3) Clean outlet valve assembly and under outlet valve disc.
 - (4) Wash mask and components with soft wet cloth to remove any hazing or dirt from mask.
 - (5) Use clear warm potable water to rinse all parts by agitating the mask and components quickly to remove all detergent.
- c. Disinfecting. Disinfecting can be accomplished as often as necessary, but as a minimum upon issue, change of user and prior to turn-in.

NOTE

Disinfecting solution is made by mixing 1 oz. (30 milliliters) household bleach per 2 gallons (7.5L) water. Quantity of disinfecting solution required is variable depending on size of container used to allow complete immersion of mask into solution.

- (1) Mask must prepared and cleaned in accordance with paragraph 5.5.a. and 5.5.b.

NOTE

Disinfecting solution and rinse water must be replaced after approximately 20 masks have been disinfected or more often if needed.

- (2) Immerse mask in disinfecting solution. Soak and swirl in disinfecting solution for 5 minutes.
- (3) Rinse mask twice in clean potable water and swirl 2 to 3 minutes.
- (4) Utilizing canteen, disinfect drink tube assembly as follows:
 - (a) Fill canteen with disinfecting solution. Cap and shake canteen.
 - (b) Push external drink tube coupling into canteen cap making sure it is seated completely.
 - (c) Turn up canteen, squeeze sides of canteen forcing the solution through the drink tube until canteen is empty.
 - (d) Remove canteen from mask.
 - (e) Rinse canteen with clean potable water twice.
 - (f) Fill canteen with clear potable water, repeat steps (b), (c) and (d).
 - (g) Dry mask and components with lint free cloth.
 - (h) When mask is completely dry reassemble mask and all components.

NOTE

Multiple mask (optional). To clean large quantities of individual masks, you must use the newer production model M1 (See Figure 5-10) canteen cap (NSN 8465-00-930-2077, which is equipped with a funnel shaped extension at the bottom). The cap can be adapted with a 3/16-inch outside diameter (O.D.) brass tube. This brass tube is fitted into a piece of rubber or plastic tubing (length as determined by user) and then fitted on the opposite end with any number of fittings (e.g. standard automotive) that would allow connection to a pressure container (e.g. plant sprayer). After attaching the external drink tube coupling of the mask to be sanitized, attach a suitable overflow tube to

T.O. 14P4-15-1

the internal drink tube, then place the opposite end in a suitable overflow receptacle. Pressurize the container, then open the valve on the pressure container, forcing the solution through the drink tube system and into a suitable receptacle. When finished, thoroughly flush the container with clean water. Now flush clean water through the drink system as described above (See Figure 5-1).

5.6 To clean the carrier, brush any dirt or grit from carrier using a brush dipped in clean cool water.

5.7 REPAIR OR REPLACEMENT.

Maintenance actions in this chapter are limited to replacement of defective mask parts. Only those parts that may be replaced are addressed. Defective parts other than those listed are cause for mask condemnation.

5.8 HEAD HARNESS/SKULL CAP REPLACEMENT.

- a. Removal - To remove the head harness/skull cap work straps out of buckles. Take out tips at an angle.
- b. Installation - To install the head harness/skull cap harness proceed as follows:

NOTE

The elastic webbing on head harness that joins the two forehead straps should be positioned at the top of the facepiece and on the outside of the harness. Seams on skullcap should be positioned to the outside.

- (1) Position new harness/skullcap in facepiece with straps next to correct buckles.
- (2) Push tips into buckles at an angle. Work straps through buckles about one inch.
- (3) Stretch each harness/skullcap strap away from facepiece. Check that buckles hold straps tight.

5.9 SIDE VOICEMITTER REPLACEMENT.

(Figure 5-3).

- a. Removal - To remove the side voicemitter proceed as follows:
 - (1) Using the straight side of carrier shoulder strap D-ring, unscrew and take out voicemitter retaining ring.
 - (2) Reach inside mask and push out voicemitter.
 - (3) Remove gasket.
- b. Installation - To install the side voicemitter proceed as follows:



The side voicemitter must be installed using a serviceable gasket. Use of an UNSERVICEABLE gasket could result in leakage of toxic agents causing illness or death.

- (1) Place serviceable (not damaged, e.g. Cut, Torn, etc.) gasket into port on facepiece and gently press into place.

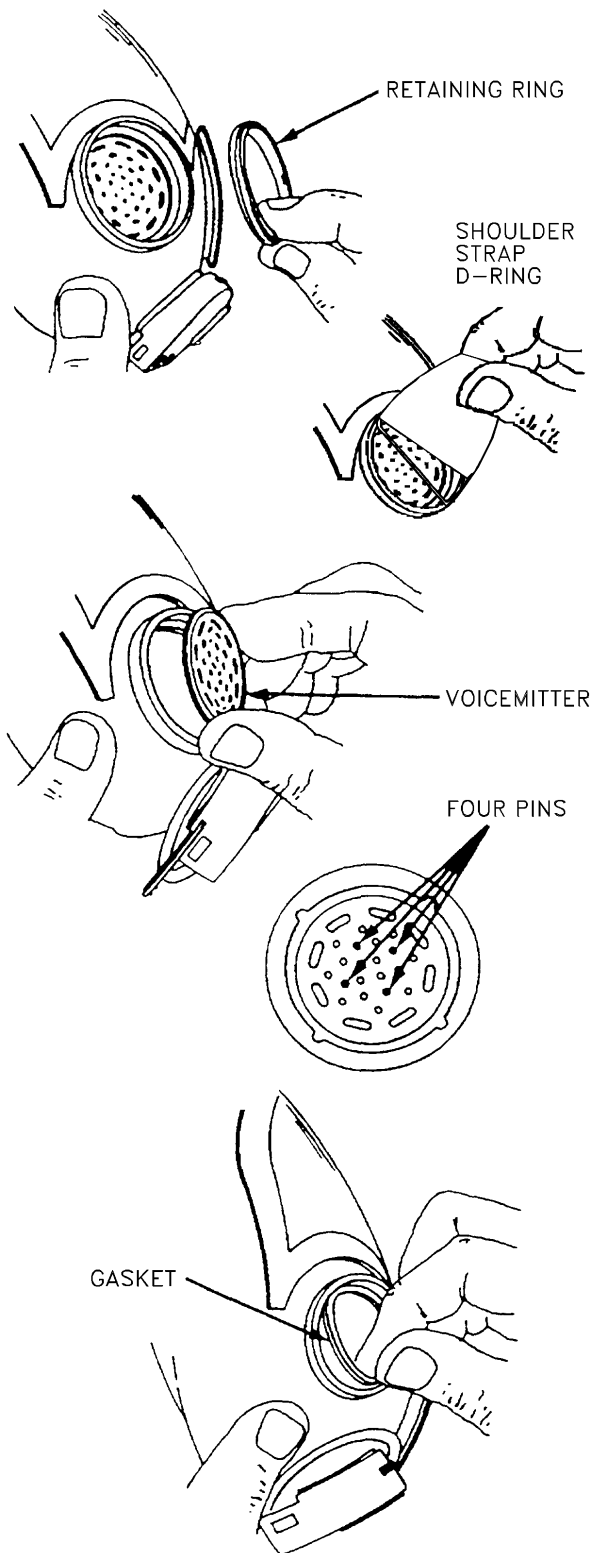
WARNING

Make sure side voicemitter is installed with the flange and four pins facing outward. Incorrect installation will result in leakage of toxic agents into the mask causing illness or death.

- (2) Put voicemitter into port with flange and four pins pointing towards outside of mask.
- (3) Screw in retaining ring (slots outward) and hand-tighten using carrier D-ring.
- (4) Perform Negative Pressure Check. Refer to paragraph 3.7.

5.10 OUTLET VALVE COVER REPLACEMENT.

(Figure 5-4.)

- a. Removal - To remove the outlet valve cover proceed as follows:
 - (1) Pull out drinking tube coupling from outlet valve cover.
 - (2) Pull cover tab down and gently peel cover away from outlet valve body.
 - (3) Stretch cover sideways to remove cover from stud.
- b. Installation - To install the outlet valve cover proceed as follows:
 - (1) Slip cover onto stud on top of outlet valve body. Fit cover over valve body.
 - (2) Push drinking tube coupling firmly into drinking tube stowage receptacle.

L9700002

Figure 5-3. Side Voicemitter Replacement

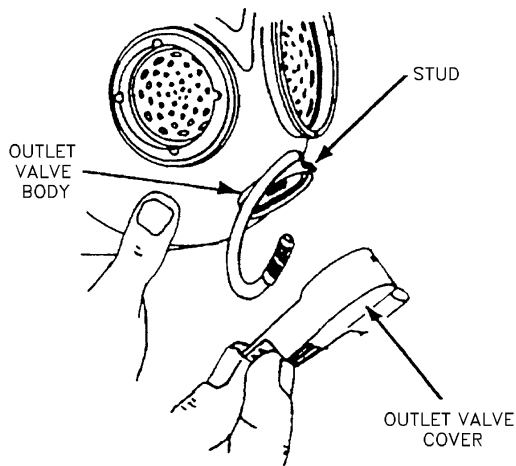

L9700003

Figure 5-4. Outlet Valve Cover Replacement

5.11 OUTLET VALVE DISC REPLACEMENT.

(Figure 5-5.)

- a. Removal - To remove the outlet valve disc proceed as follows:
 - (1) Pull out drinking tube coupling from cover.
 - (2) Pull cover tab down and gently peel cover away from outlet valve body stud.
 - (3) Stretch cover sideways to remove cover from stud.
 - (4) Hold disc between thumb and fore-finger and gently pull from valve body. Discard disc.

- b. Installation - To install the outlet valve disc proceed as follows:

WARNING

Failure to use the outlet valve disc with supportive screen (Figure 5-5) may allow toxic vapors into the mask.

- c. Push stem of disc through hole in center of valve body while pulling the stem from inside the mask until the stem shoulder seats in valve body.
- d. Smooth and flatten disc so that it touches valve body all around edge. Gently rotate disc to be sure it is seated correctly.

NOTE

If disc does not rotate, it is not correctly seated.

- e. Slip cover onto stud on top of outlet valve body. Fit cover over valve body.
- f. Push drinking tube coupling firmly into drinking tube stowage receptacle.
- g. Perform Negative Pressure Check. Refer to paragraph 3.7.

5.12 INLET VALVE ASSEMBLY REPLACEMENT.

(Figure 5-6.)

- a. Removal - To remove the inlet valve assembly proceed as follows:
 - (1) Unscrew and take off canister.
 - (2) Gently push center of valve body until it pops through port.
 - (3) Remove assembly from inside facepiece.

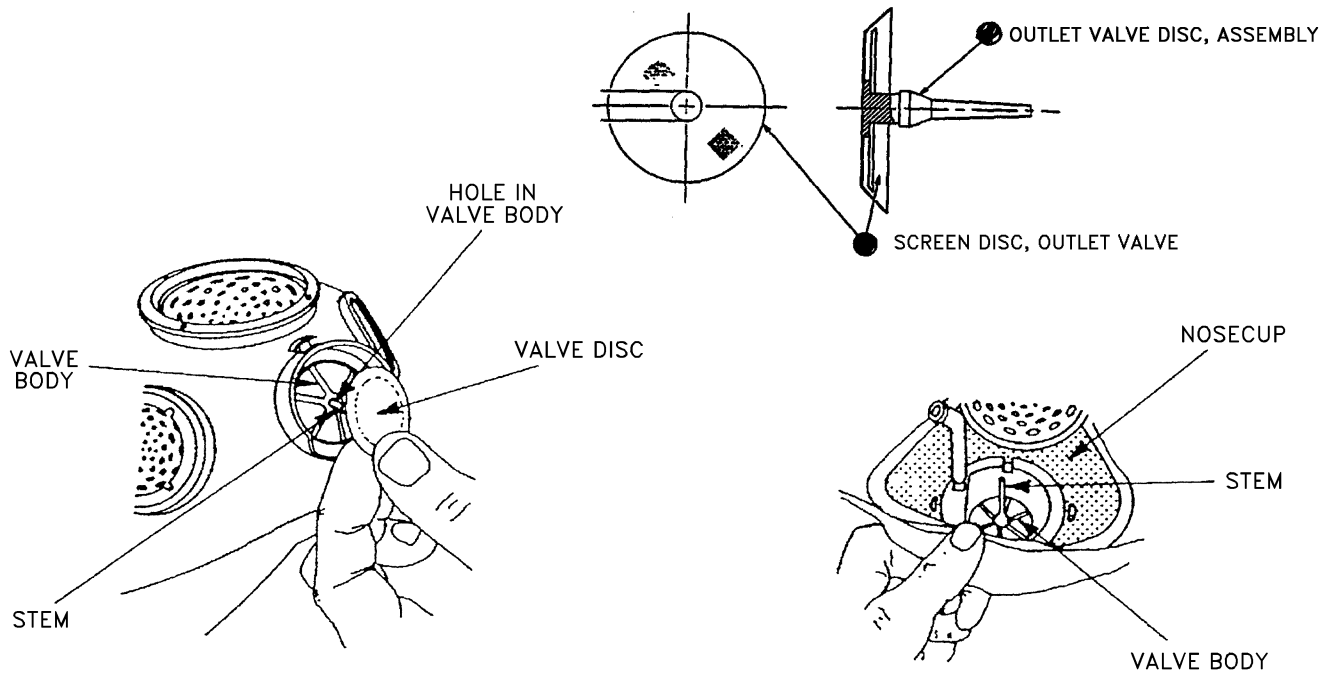

L0004081

Figure 5-5. Outlet Valve Disc Replacement

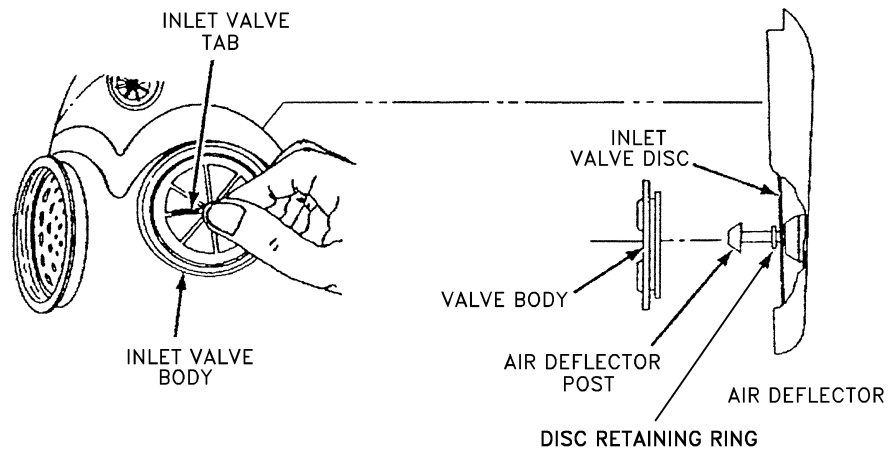

L0004082

Figure 5-6. Inlet Valve Assembly Replacement

T.O. 14P4-15-1

- (4) Remove valve body from air deflector post.
 - (5) Lift disc off post. Discard disc.
- b. Installation - To install the inlet valve assembly proceed as follows:
- (1) Push valve body into port. Be sure tabs face outward and groove in body seats in rim of port.
 - (2) Press disc onto post of air deflector assembly until it seats behind disc retaining ring (Figure 5-6).
 - (3) From inside facepiece, push air deflector assembly into valve body while holding valve body in port. Head of air deflector post must stick through hole in center of valve body. Side edges of air deflector shall be between the raised parallel guides on inside of facepiece.
 - (4) Rotate valve body using tabs to verify correct seating.
 - (5) Screw canister into mask handtight.
 - (6) Perform negative pressure check. Refer to paragraph 3.7.

5.13 NOSECUP VALVE DISC REPLACEMENT.

(Figure 5-7.) Repeat steps if more than one disc requires replacement.

- a. Removal - To remove the nosecup valve disc proceed as follows:
- (1) Turn head harness of mask inside out for access to nosecup.
 - (2) Curl back lip of nosecup to expose nosecup valves.
 - (3) Raise edge of valve disc. With forefinger and thumb, lift edge of disc. Gently pull disc from hole in center of valve seat.
- b. Installation - To install the nosecup valve disc proceed as follows:
- (1) Hold disc between thumb and forefinger.
 - (2) Curl back lip of nosecup to expose nosecup valve seat. Push stem of disc through hole in center of valve seat so that disc will be on the inside of nosecup.
 - (3) To seat disc, grasp the stem and pull outward until the shoulder slips through hole in the valve seat.

- (4) Smooth disc so that it lies flat. Gently rotate disc with finger to be sure disc does not bind and is seated correctly.

5.14 EXTERNAL DRINKING TUBE REPLACEMENT.

(Figure 5-8.)

- a. Removal - To remove the drinking tube proceed as follows:
- (1) Unscrew and remove canister.
 - (2) Pull out drinking tube coupling from outlet valve cover.
 - (3) Pull cover tab down and gently peel cover away from outlet valve body.

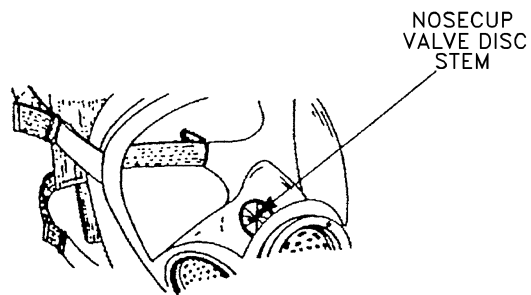
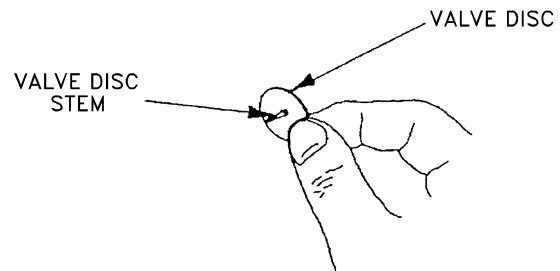

OUTSIDE VIEW

L0004083

Figure 5-7. Nosecup Valve Disc Replacement

- (4) Stretch cover sideways to remove cover from stud.
- (5) Grasp tube and pull off from feed-through pipe.

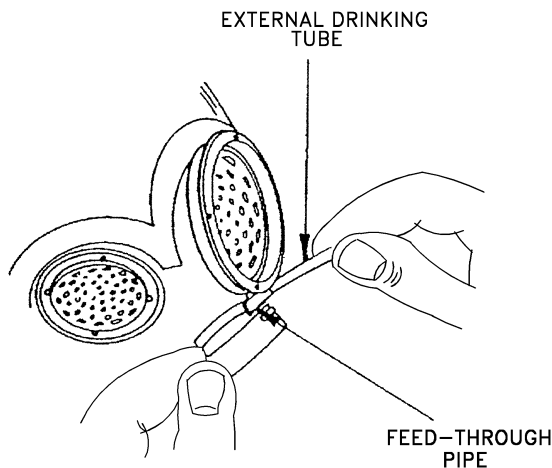

L0004084

Figure 5-8. External Drinking Tube Replacement

- b. Installation - To install the drinking tube proceed as follows:
- (1) Push and twist tube onto feed-through pipe. Be sure end of tube is pushed fully onto feed-through pipe.
 - (2) Slip cover onto stud on top of outlet valve body. Fit cover over valve body.
 - (3) Push drinking tube coupling firmly into drinking tube stowage receptacle.
 - (4) Screw canister into mask and handtighten.
 - (5) Perform Drink Tube Leak test. Refer to paragraph 3.6.
 - (6) Perform Negative Pressure Check. Refer to paragraph 3.7.
 - (7) Test drinking tube. Refer to paragraph 4.19.

5.15 INTERNAL DRINKING TUBE REPLACEMENT.

- a. Removal - To remove the internal drink tube, pull the tube off of the fetcher pipe on the outlet valve body.

- b. Installation - To install the internal drinking tube, proceed as follows:
- (1) Clean fetcher pipe connector.
 - (2) Push and twist tube onto fetcher pipe. Be sure end of tube is pushed fully onto fetcher pipe.
 - (3) Perform drink tube leak check. Refer to paragraph 3.6.
 - (4) Perform Negative Pressure Check. Refer to paragraph 3.7.

5.16 NOSECUP VALVE SEAT REPLACEMENT.

Repeat steps if more than one valve seat requires replacement.

- a. Removal - To remove the nosecup valve seat proceed as follows:
- (1) Turn head harness/skullcap of mask inside out for access to nosecup.
 - (2) Using fingertips, gently push nosecup valve seat toward inside of nosecup.
- b. Installation. - To install the nosecup valve seat proceed as follows:
- (1) With spoked side of nosecup valve seat facing inside of nosecup area, place bottom edge of nosecup seat into nosecup valve seat opening.
 - (2) Gently work edge of nosecup opening into groove of nosecup seat until entire circumference of opening is seated into nosecup valve seat groove.

5.17 RE-TORQUING/REPLACEMENT OF THE FRONT VOICEMITTER (FIGURE 6-1, INDEX 18).

CAUTION

It is imperative that front voicemitter only be torqued to 85 in-lbs, over torquing will damage mask.

NOTE

It is essential that this repair occur under controlled conditions: TDA 99M trained operator, TDA 99M leak tester, specified torque wrench and specified front voicemitter tool only.

- a. Remove the lense outsert (Figure 6-1, Index 5) so the retaining ring is easily accessible.

T.O. 14P4-15-1

- b. Using the specified tool, loosen the retaining ring by inserting the four pins on the tool into the four holes in the retaining ring.
- c. Remove front voicemitter from mask by turning in the counter clockwise direction. Pay close attention to the position of the micmitter and the indentation made by the micmitter. (MCU-2A/P ONLY).
- d. Clean rubber seal (this seal is not removable) and front voicemitter to include the threaded housing in accordance with paragraph 5.5.
- e. Reinstall voicemitter
 - (1) Hand tighten initially by turning in the clockwise direction. Make sure the micmitter (MCU-2A/P ONLY) is at the 5:30 position so that it will end up being at the six O'clock position or lined up with the same indentation made by the voicemitter during initial torquing.
 - (2) Mount mask on the TDA 99M head form, using the specified torque wrench and specified front voicemitter tool, (Chapter 2 Special Tools and Test Equipment) tighten to 85 in-lbs. It is essential that the position of the micmitter (MCU-2A/P) matches its original position (either six O'clock or where the original indentation had been made.
 - (3) Remove mask from TDA 99M.
- f. Using a non-permanent marker, place two a reference marks aligned with each other on the mask and voicemitter retaining ring.
- g. Let the voicemitter rest for a minimum of 4 hours. Check to see if marks are still aligned with each other. If not, retorque to 85 in-lbs.
- h. Test mask for leakage using a TDA 99M.
 - (1) If the mask does not pass the leakage test, isolate the failure and repair as required in accordance with Table 5-1 and retest. If the mask still leaks around the front voicemitter, replace the front voicemitter with one from

another condemned mask, or replace with a new front voicemitter with retaining ring (part No. 88115035-2) and repeat steps b. through h. above.

- (2) If the mask fails the second leakage test and reason for failure can not be determined, it should be disposed of in accordance with distribution instructions provided by the Item Manager.

5.18 M101/A1C OR SIMILAR TYPE MICROPHONE INSTALLATION.

- a. Installation - To install the microphone proceed as follows:
 - (1) Place mask on a flat surface, with head harness facing toward you.
 - (2) Position head harness so you can easily work on the inside area of mask.
 - (3) Find and examine microphone connector assembly located inside the mask, attached to the front voicemitter (see Figure 5-9).
- CAUTION**
- To avoid damaging the connector assembly, use caution when repositioning. Move connector wires forward and backwards ONLY, do not move wires laterally. Wires are to always remain in the one O'clock position, when viewed from the rear, looking into mask as though you were putting mask on (see Figure 5-9).
- (4) Position microphone connector pins so that the microphone can be easily attached.
 - (5) Place microphone, with the word "Front", facing where mouth will be positioned when wearing mask. Slide microphone all the way up the pins until microphone stops (see Figure 5-9).

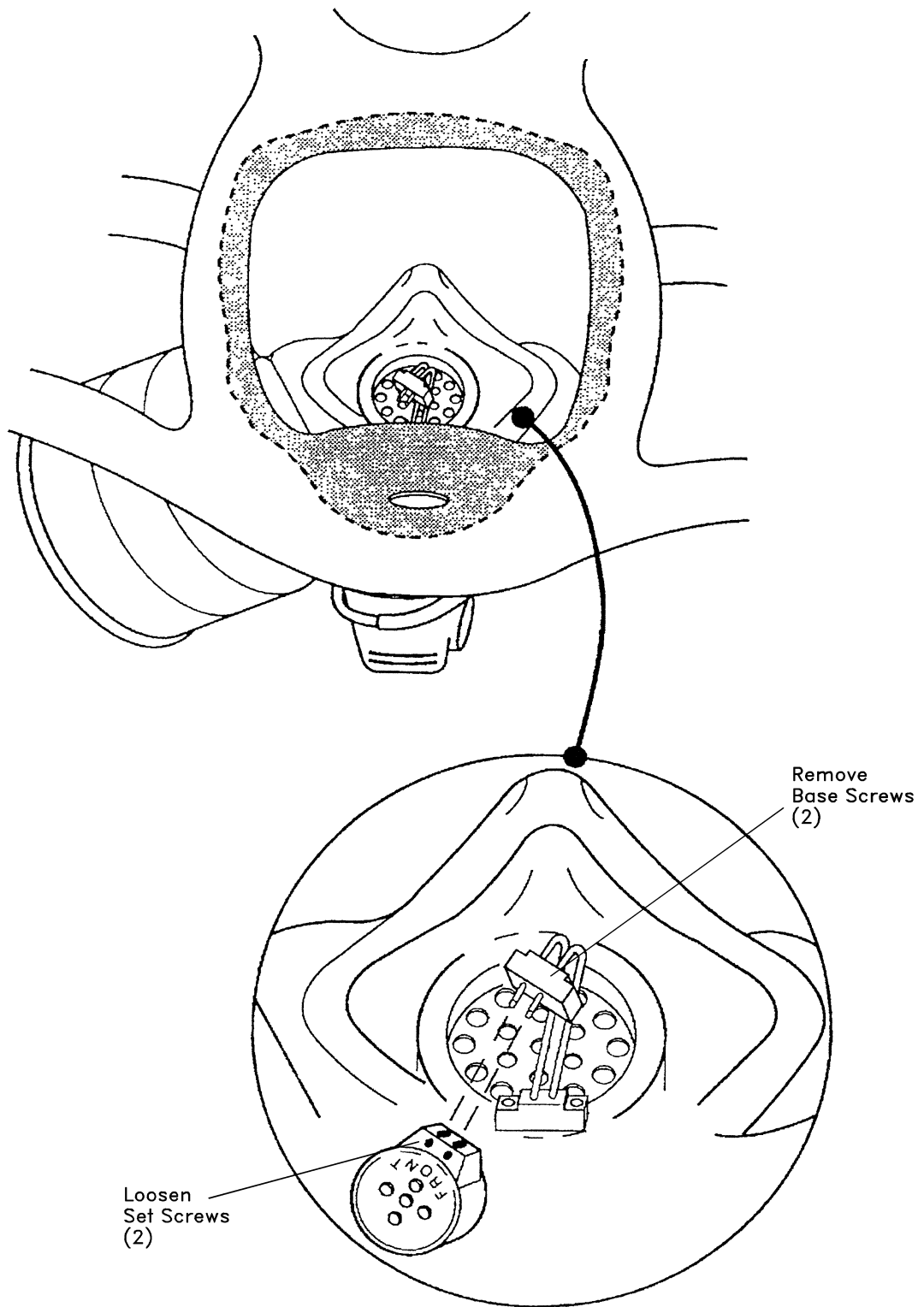

L0004075

Figure 5-9. MCU-2A/P Microphone Installation

T.O. 14P4-15-1

- (6) Tighten two set screws located at base of microphone using a 0.066 wide bladed screwdriver if using a M101/1C microphone. Other microphones use a hexhead set screw. This requires a hexwrench to tighten the set screws. The set screws when tight will lock microphone in place.
 - (7) Check mask microphone with a compatible working communications system and test the system to make sure that everything is in working order.
 - (8) Some microphones are available with an additional attachment by means of two 2-56 screws. These two screws are assembled through holes in the microphone connector and threaded into the base of the microphone housing.
 - (9) Position microphone in a comfortable position close to the clips. The two black connector wires are flexible and can be positioned easily.
- b. Upgrading H-133 Headset-Microphone to Allow Connection to MCU-2A/P Gas Mask.

NOTE

Some noise suppression headset-microphone sets H-133, part No. M87819/1-01 NSN 5965-01-204-8505 do not have plug connectors between the headset and microphone assemblies, thus not allowing the connection of mask's internal microphone.

- (1) Upgrade H-133 headset assemblies, to conform with the latest change to the specification as follows:
 - (a) Order plug assemblies 172/U, part No. 102950, NSN 5935-01-125-4897, and U173/U, part No. 119563, NSN 5935-00-888-5351.
 - (b) Cut microphone cord halfway between the headset and the microphone assembly, install the female plug U172/U on the headset half of the lead and the male U173/U on the microphone lead.
 - (c) Use adapter lead CX4434/U, part No. 31500, NSN 5995-00-890-8614, or equivalent as needed, to reach microphone plug.
- (2) This work must be accomplished by a person qualified in electrical/electronic soldering, following standard maintenance procedures.

5.19 OUTSERT RUBBER STRAP REPLACEMENT.

- a. Removal - Pull on ends of rubber strap until they pop loose.
- b. Installation - Push in ends of rubber strap into holes on outsert until they enter fully. Remove any excess stem as required.

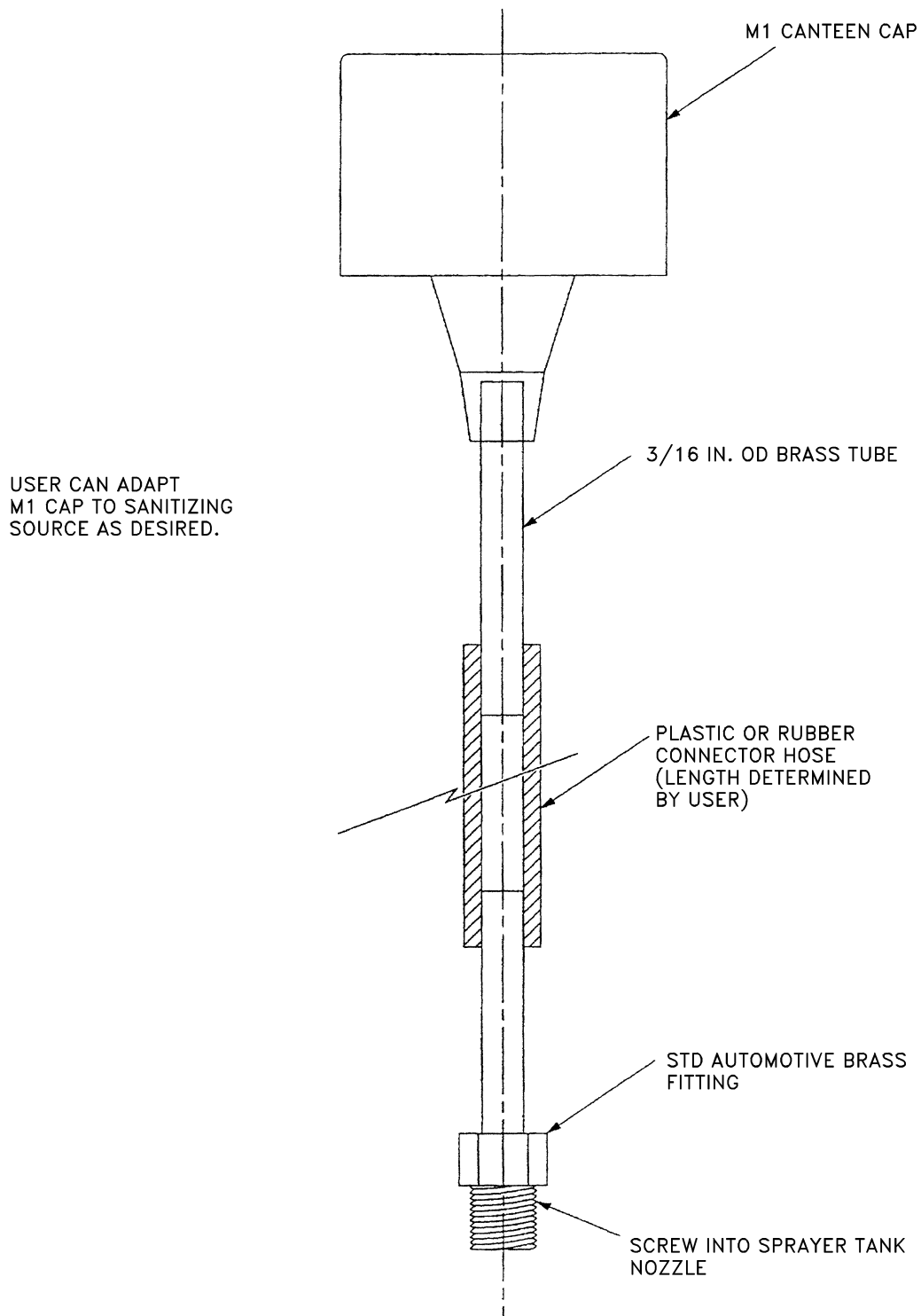

L0004076

Figure 5-10. Optional Drink Tube Adapter

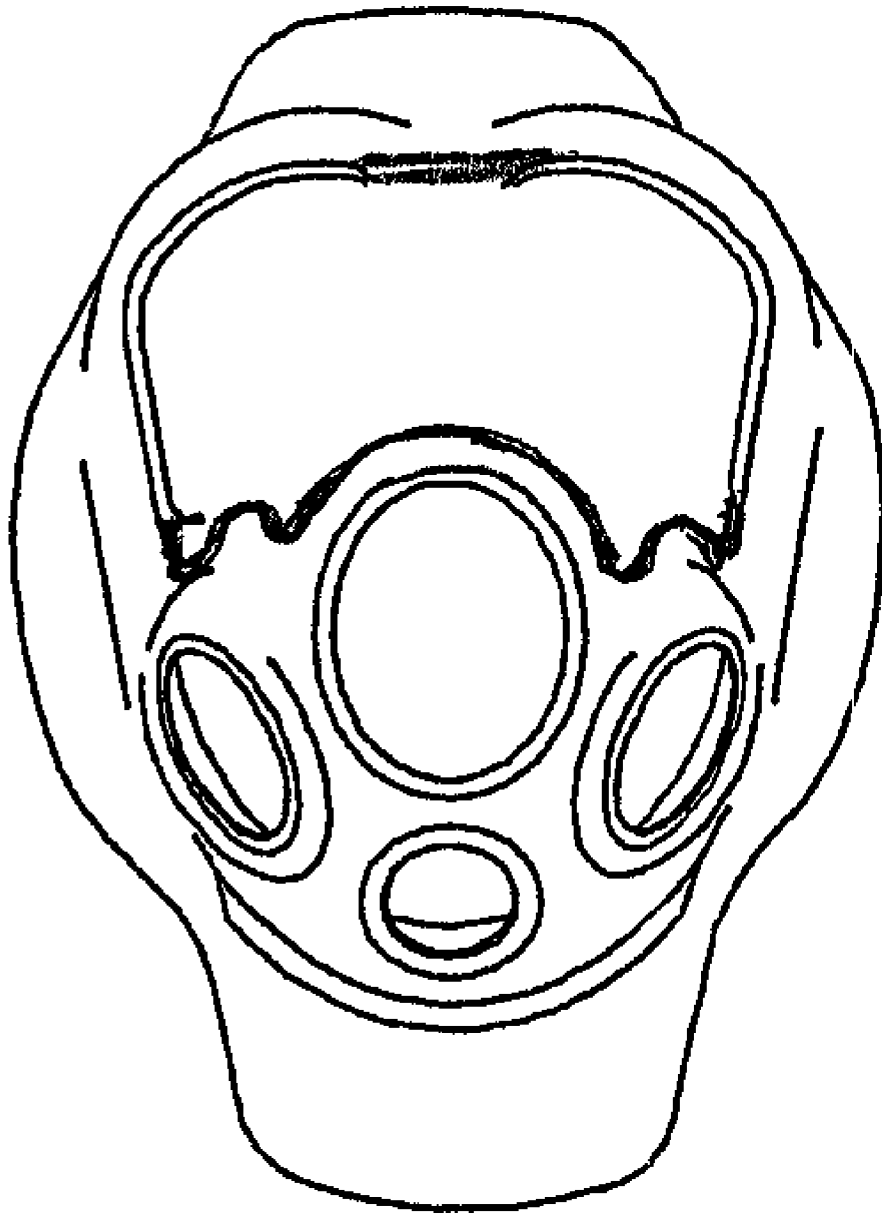

L0309397

Figure 5-11. Second Skin

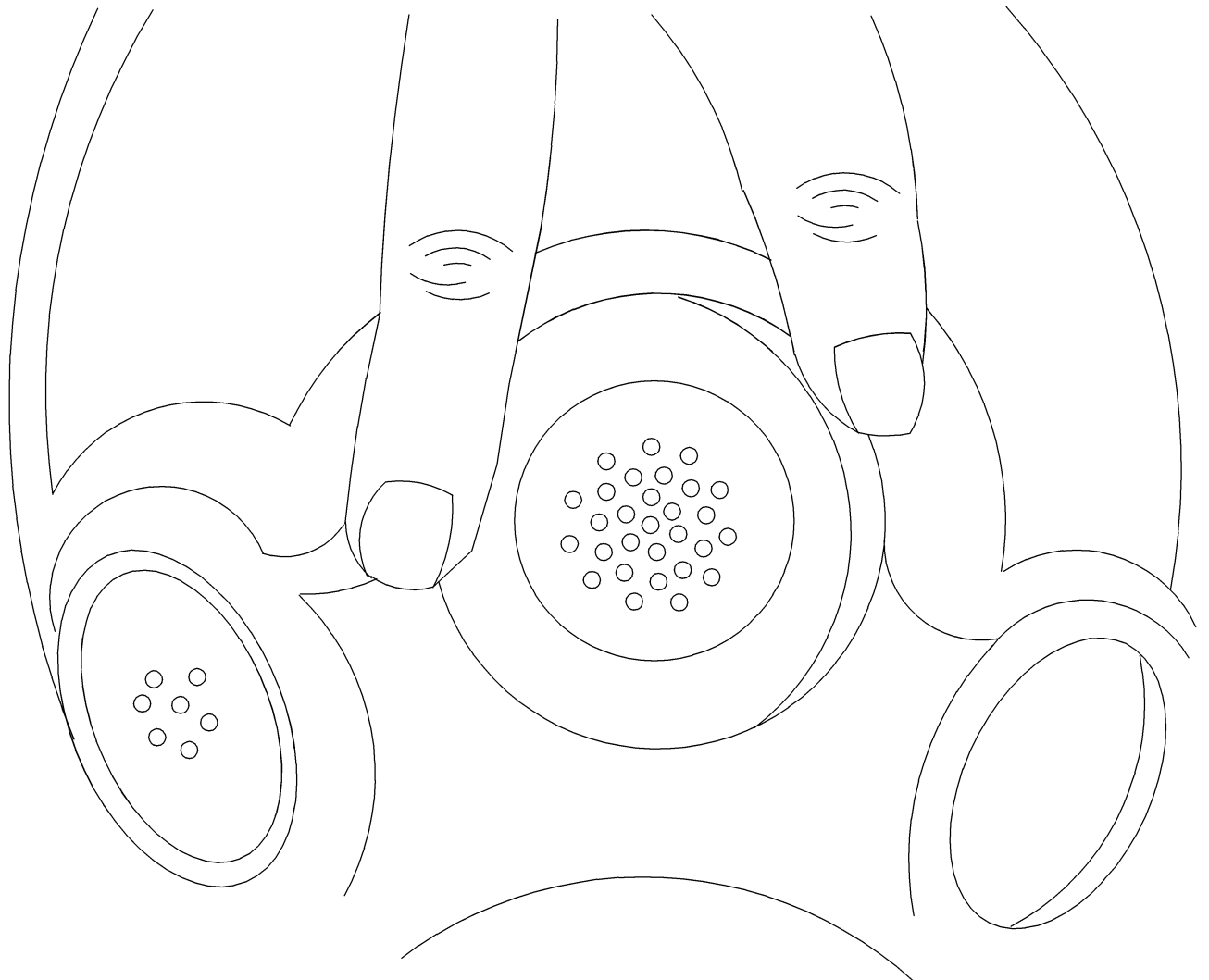

L0004078

Figure 5-12. Front Voicemitter Inspection

T.O. 14P4-15-1

5.20 MCU-2 SERIES SECOND SKIN.

(Figure 5-11)

a. Installation.

NOTE

- The Second Skin should be used with the M-40 side voicemitter retaining ring NSN 5365-01-260-8700. This ring has a wider flange than the one used on the MCU-2 Series mask. Refer to T.O. 14P4-15-1, paragraph 5.9 for removal/installation instructions.
- Prior to installing Second Skin, make sure you have the correct size. (M/L for medium and large masks and S for small masks. Size is annotated on the outer left side.

b. Installing the Second Skin (SS).

- (1) Remove filter canister.
- (2) Remove detachable microphone (MCU-2P Masks only) if mounted. (Paragraph 5.22)
- (3) Remove eyelens outsert.
- (4) Remove drinking tube from stowage receptacle on outlet valve cover.
- (5) Remove outlet valve cover.
- (6) Remove temple straps from the head harness/skull cap.
- (7) Orient the Second Skin with large rib at bottom and facing outward.
- (8) Place Second Skin on top of mask.

CAUTION

Avoid overstretching holes in the Second Skin. Use caution when pulling Second Skin over flanges of outlet valve and side voicemitter retaining ring.

- (9) Pull drink tube through the lower center hole (outlet valve body hole) on the Second Skin.

WARNING

Do not damage outlet valve disk while stretching Second Skin over the outlet valve body.

- (10) Stretch lower center hole of Second Skin over the outlet valve body and position Second Skin so that it is under the drink tube.
- (11) Stretch Second Skin over the M-40 side voicemitter retaining ring (if installed).

CAUTION

Use caution when stretching Second Skin over the lens to avoid tearing the Second Skin.

- (12) Stretch the sides and top of the large opening over the lens and position it so that the narrow rib fits into groove adjacent to where lens and mask are bonded together.
- (13) Pull the two temple straps up through the slots in the Second Skin and attach to head harness/skull cap.
- (14) At this time, the Second Skin should be centered and laying on top of the front voicemitter retaining ring. To position the Second Skin, place the thumbs at the bottom of the front voicemitter and work the Second Skin around the retaining ring so that it is flush with the top of the retaining ring.
- (15) Adjust Second Skin as needed to make sure you have as much of the mask covered as possible around the side voicemitter and the inlet valve.

WARNING

Do not use Second Skin without the eyelens outsert installed. Second Skin will not stay reliably positioned without it.

- (16) Install eyelens outsert, make sure Second Skin is positioned under the outset tabs.
- (17) Install outlet valve cover and push drink tube coupling firmly into stowage receptacle.

CAUTION

When installing canister, make sure Second Skin does not get pulled down inside the threaded area.

- (18) Install filter canister.
- (19) Install detachable microphone (if required). See paragraph 5.21.

WARNING

Second Skin can not be changed in a contaminated environment.

- c. Removing non-contaminated Second Skin. To remove non-contaminated Second Skin follow the installation instructions in reverse order.
- d. Removing contaminated Second Skin.

CAUTION

When using a sharp instrument to remove Second Skin, be sure you only cut the Second Skin and not the mask or straps.

- (1) Remove eyelens outsert.
- (2) Cut the two slots where the temple straps go through the Second Skin.
- (3) Cut the Second Skin at the top of the front voicemitter and between the front voicemitter and the top of the outlet valve housing.
- (4) Cut the Second Skin between the large eyelens opening and the opening for the canister and the side voicemitter.
- (5) Remove Second Skin and dispose of in accordance with local standard operating procedures (SOP) for disposing of contaminated equipment.

- (6) In a Contamination Control Area (CCA) replace hood, Second Skin and outsert.

5.21 DETACHABLE MICROPHONE INSTRUCTIONS.

Installing detachable microphone (only for MCU-2P masks)

- a. Hold facepiece in your hand with the front voicemitter facing you.
- b. Hold detachable microphone clip in your hand with the ring opening facing down, and the flat surface facing towards the facepiece.
- c. Insert the clip into the voicemitter housing with the cord at the six O'clock position.
- d. Snap the clip into place by pushing on the microphone casing, making sure it is flush against the front voicemitter.

5.22 REMOVING DETACHABLE MICROPHONE.

- a. Hold the facepiece in your hand with the front voicemitter facing you.
- b. Place index finger on either side of the microphone at the three O'clock position or nine O'clock position. Apply a sideward force until extracted.

CHAPTER 6 ILLUSTRATED PARTS BREAKDOWN

SECTION I FOREWORD

6.1 GENERAL.

This chapter contains the Illustrated Parts Breakdown (IPB) which assists the supply and maintenance personnel in the identification and requisitioning of replaceable parts.

6.2 PURPOSE.

The Illustrated Parts Breakdown (IPB) is prepared to assist supply and maintenance personnel in the identification, requisitioning and stocking of replaceable parts. The IPB is not intended to be used as a authority for procedure of disassembly or assembly. Maintenance or repair should be performed by authorized personnel using the applicable maintenance sections of this manual

6.3 INTRODUCTION.

The introduction contains general and specific information pertaining to use of the IPB.

6.4 GROUP ASSEMBLY PARTS LISTS.

The assemblies and parts installed at the time the MCU-2 Series mask was procured are listed and identified in the manual. When an assembly or part (including vendor items), which is different from the original, was installed during the manufacture of alter items, series, or blocks, all assemblies and parts are listed (and "Usable on" coded). However, when the original assembly or part does not have continued application (no spares are no longer authorized for replacement), only the preferred assembly or part is listed. Also, when an assembly or part was installed during modification, and the original does not have continued application, only the preferred item is listed. When a standard size part, the latter parts, showing sizes, are also listed. Repair Parts Kits and Quick Change Units are listed when they are available for replacement.

6.5 MAINTENANCE PARTS LIST.

This MPL describes, and illustrates the assemblies, subassemblies and detail parts of the MCU-2 Series mask.

6.6 MODELS COVERED.

MCU-2A/P and MCU-2P

6.7 ABBREVIATIONS AND SYMBOLS.

All abbreviations used in this publication are contained in the following list:

<u>ABBREVIATIONS</u>	<u>DEFINITION</u>
Assy	Assembly
Ave.	Avenue
CAGE	Commercial and Government Entity
CB	Chemical Biological
°F	Degrees Fahrenheit
I & S	Interchangeable and Substitute
IAW	In Accordance With
IPB	Illustrated Parts Breakdown
MPL	Maintenance Parts List
NSN	National Stock Number
PN	Part Number
RC	Riot Control
SMR	Source, Maintenance and Recoverability

6.8 COMMERCIAL AND GOVERNMENT ENTITY (CAGE).

This column lists the code of the manufacturer or supplier of the part listed in the Part number Column. Refer to the handbook of commercial and Government Entity codes. Cataloging Handbook H4/H8 for all manufactures supplying items or articles not carried under prime contractor's part numbers.

6.9 NUMERICAL LISTING.

All CAGE listed in the CAGE column of the Maintenance Parts List (MPL) are arranged in numerical sequence with the complete name and address of the appropriate manufacturer or Government Agency following each CAGE as follows:

T.O. 14P4-15-1

CAGE	NAME AND ADDRESS
03038	Long-Lok Fasteners Corp 13709 S Normandie Ave Gardena, CA 90249-2609
16575	Sonetronics Inc 1718 H Street PO Box L West Belmar, NJ 07719-3140
53655	Scott Aviation A Div. of Scott Technologies Inc. 225 Erie Street Lancaster, NY 14086-9502
55799	Mine Safety Appliance Company 3880 Meadowbrook Road Murrysville, PA 15668
81349	Military Specifications Promulgated by Military Departments/Agencies Under Authority of Defense Standardization Manual 4120 3-M
92114	Scott Aviation Sierra Products Division 1900 Walker Ave Monrovia, CA 91016
98752	Warner Robins ALC Robins AFB, GA 31098

6.10 ALPHABETICAL LISTING.

All manufacturers and Government Agencies listed in the description column of the MPL are listed in alphabetical sequence as follows:

NAME AND ADDRESS	CAGE
Long-Lok Fasteners Corp. 13709 S Normandie Ave Gardena, CA 90249-2609	03038
Mine Safety Appliance Company 3880 Meadowbrook Road Murrysville, PA 15668	55799

NAME AND ADDRESS	CAGE
Sonetronics Inc 1718 H Street PO Box L West Belmar, NJ 07719-3140	16575
US Army, Soldier and Biological Chemical Command Edgewood Chemical Biological Center 5183 Blackhawk Rd. Gunpowder MD 21010-5424	81361
Warner Robins ALC Robins AFB, GA 31098	98752

6.11 USABLE ON CODE COLUMN.

This column contains suitable coding for assemblies and parts to indicate specific usability by serial, type, model, or series numbers of the articles for which the breakdown is prepared. Where the Usable On Code column has been left blank, parts listed apply to all models covered by this breakdown.

6.12 SOURCE, MAINTENANCE AND RECOVERABILITY (SMR) CODES.

Definitions of applicable Source, Maintenance, and Recoverability Codes (SMR) are set forth in T.O. 00-25-195.

6.13 APPLICABLE TIME COMPLIANCE TECHNICAL ORDERS (TCTO).

None.

SECTION II MAINTENANCE PARTS LIST

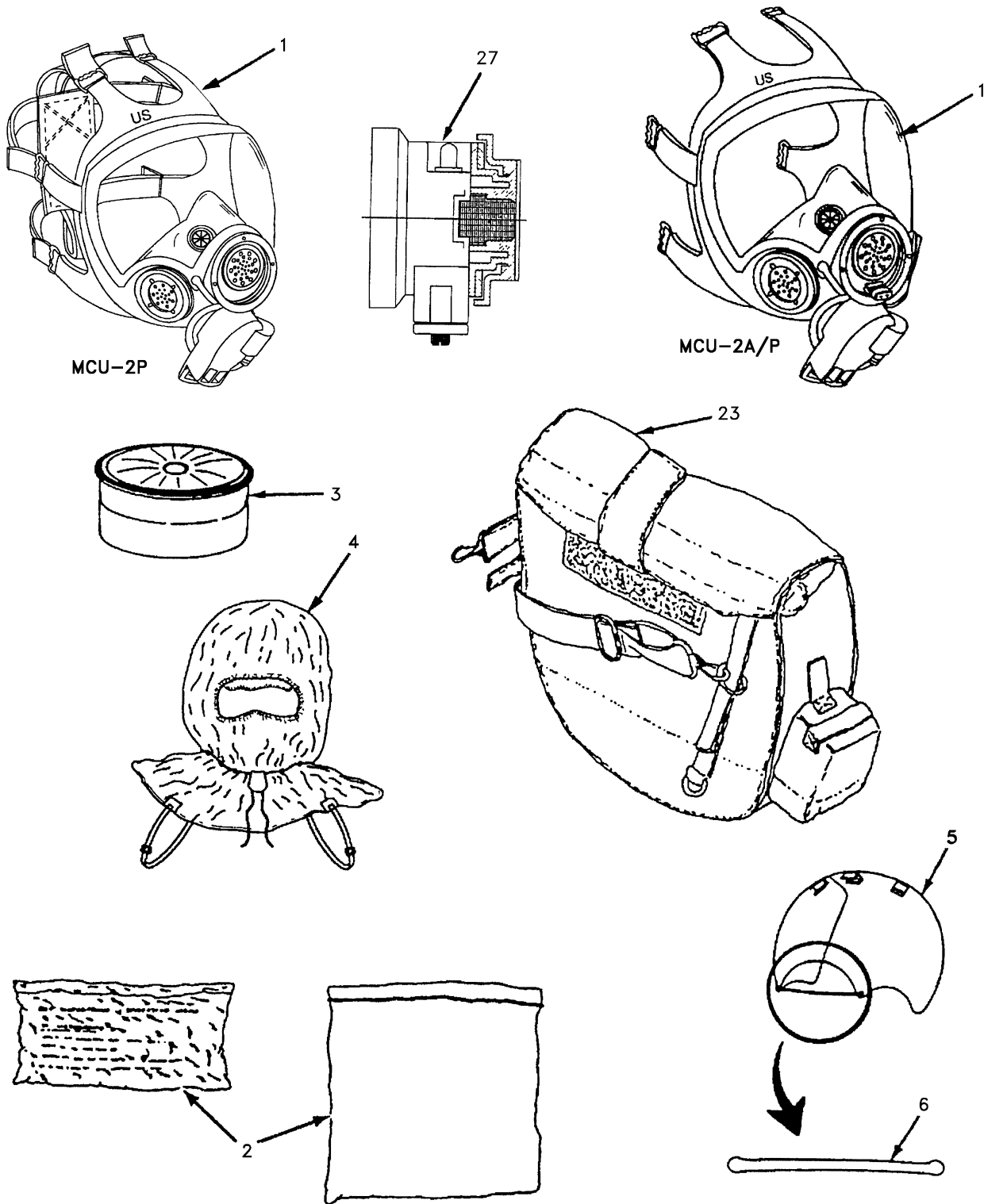

L0004106

Figure 6-1. MCU-2 Series Mask (Including Accessories) (Sheet 1 of 3)

FACEPIECE ASSEMBLY

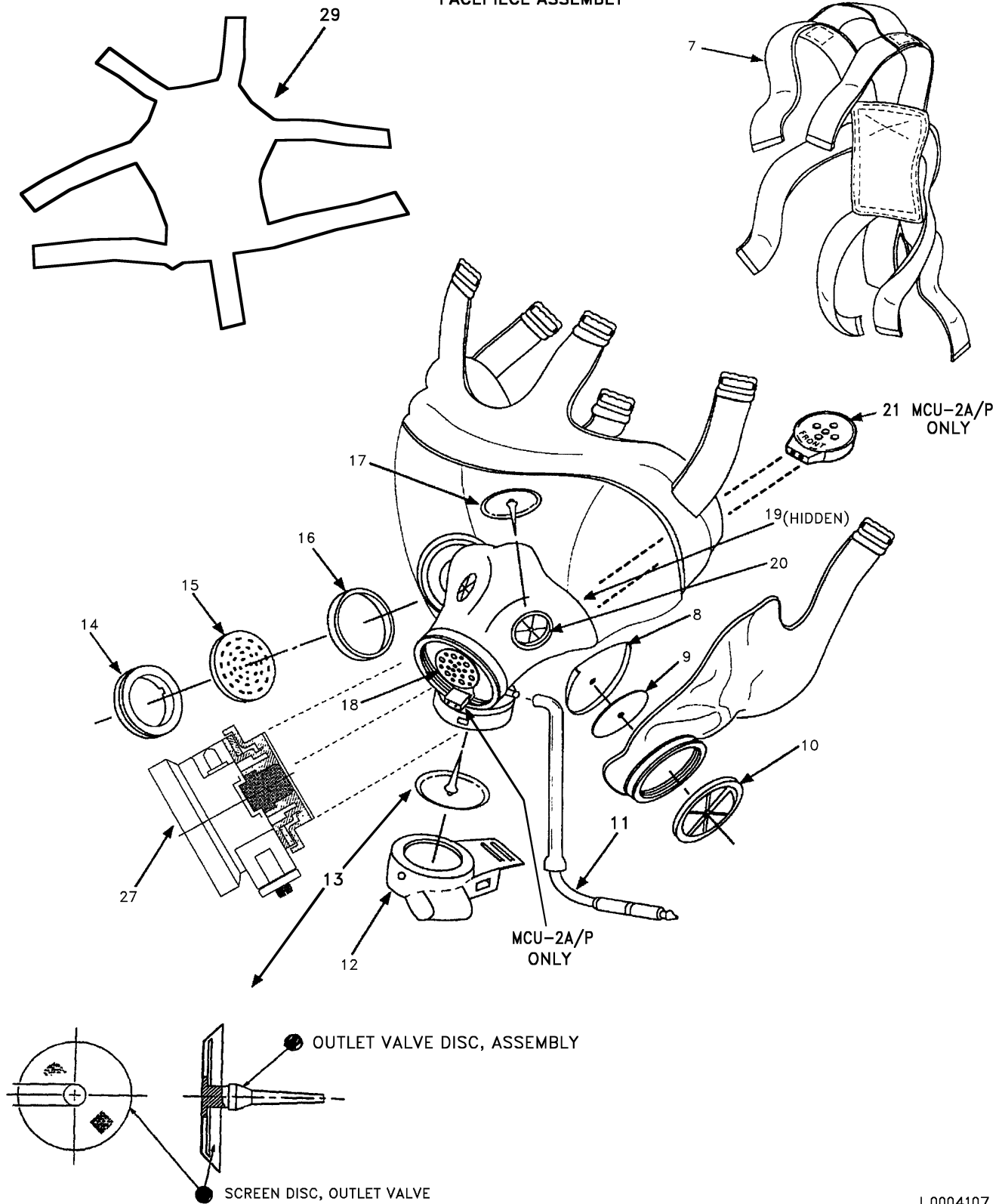

L0004107

Figure 6-1. MCU-2 Series Mask (Including Accessories) (Sheet 2)

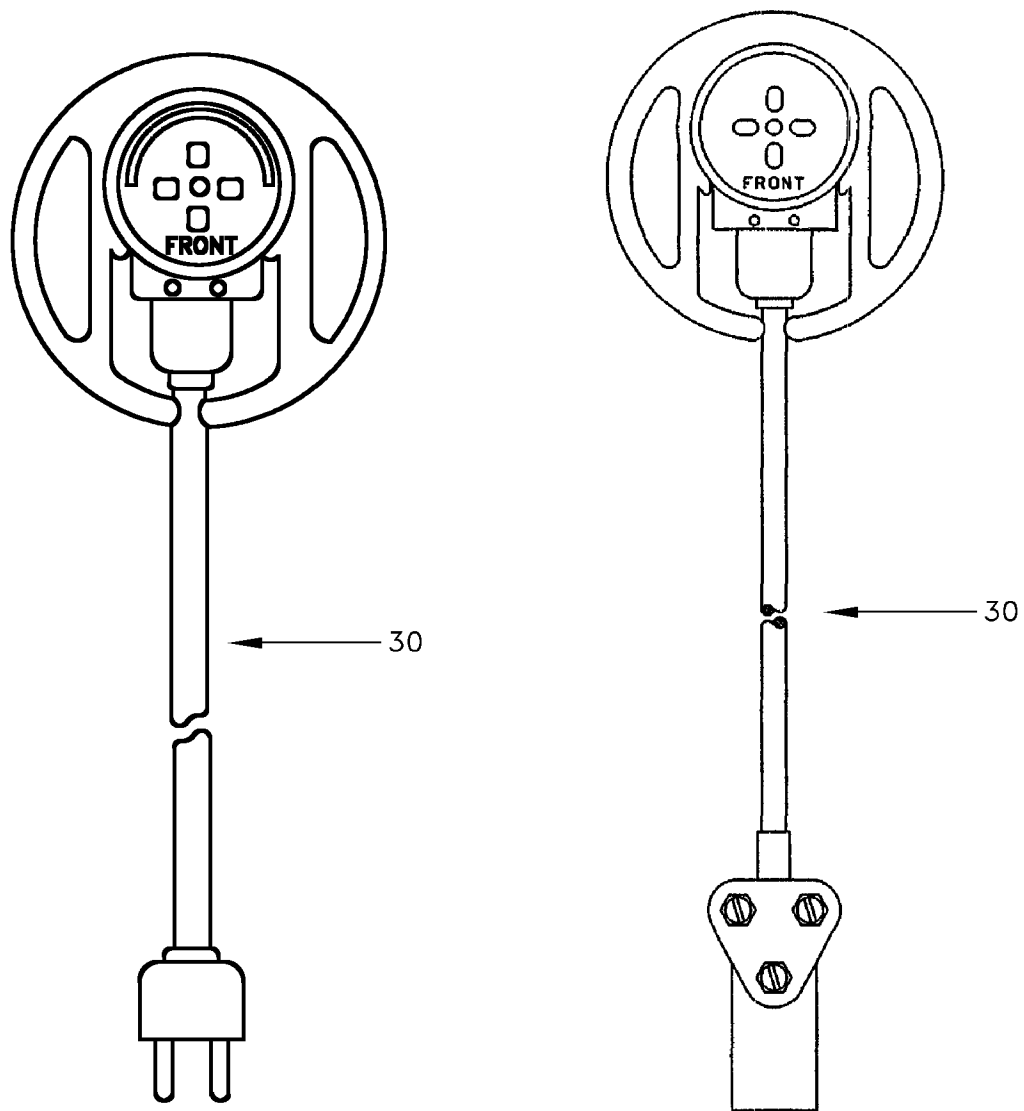

L0301965

Figure 6-1. MCU-2 Series Mask (Including Accessories) (Sheet 3)

FIGURE & INDEX/ SHEET NO.	PART NUMBER	CAGE	DESCRIPTION 1234567	UNITS PER ASSY	USABLE ON CODE	SMR CODE
6-1-1/	88115001-10	98752	MASK KIT, MCU-2/P, SHORT	1	B	AFF
	88115001-11	98752	MASK KIT, MCU-2/P, MEDIUM	1	B	AFF
	88115001-12	98752	MASK KIT, MCU-2/P, LONG	1	B	AFF
1/1	88115010-10	98752	FACEPIECE ASSEMBLY, FIELD	1		PAOFFP
			4240-01-415-4239 (SHORT)			
	88115010-11	98752	FACEPIECE ASSEMBLY, FIELD	1		PAOFFP
			4240-01-415-4240 (MEDIUM)			
	88115010-12	98752	FACEPIECE ASSEMBLY, FIELD	1		PAOFFP
			4240-01-415-4241 (LONG)			
2/1	C5-75-2	81349	BAG, WATERPROOFING	1		PAOZZN
			(4240-00-377-9401), OR BAG, ZIPLOCK (4240-00-803-5839)			
3/1	D5-3-1500	81349	CANISTER, CHEMICAL-BIOLOGICAL	7		PAOZZN
			(4240-01-361-1319)			
4/1	864-55	55799	HOOD, MASK FIELD	5		PAOZZN
			(4240-01-189-9423)			
5/1	88115074-1	98752	OUTSERT SHORT (CLEAR)	1		PAOZZN
			(4240-01-224-4195)			
	88115075-1	98752	OUTSERT, MEDIUM/LONG (CLEAR)	1		PAOZZN
			(4240-01-224-4197)			
	88115074-2	98752	OUTSERT, SHORT (TINTED)	1		PAOZZN
			(4240-01-247-9107)			
	88115075-2	98752	OUTSERT, MEDIUM/LONG (TINTED)	1		PAOZZN
			(4240-01-249-4438)			
6/1	88115073	98752	STRAP,RUBBER	1		PAOZZN
			(4240-01-464-7839)			
7/2	88115066	98752	HARNESS, HEAD	1		PAOZZN
			(4240-01-464-7839)			
8/2	88115031	98752	AIR DEFLECTOR ASSEMBLY	1		PAOZZN
			(4240-01-286-1842)			
9/2	88115052	98752	DISC, INLET VALVE	1		PAOZZN
			(4820-01-224-6336)			
10/2	88115051	98752	BODY, INLET VALVE	1		PAOZZN
			(4240-01-226-7005)			
11/2	88115054	98752	DRINKING TUBE, EXTERNAL	1		PAOZZN
			(4240-01-286-1841)			
12/2	88115065	98752	COVER, OUTLET VALVE	1		PAOZZN
			(4240-01-241-4913)			
13/2	88115064	9137683	DISK, OUTLET VALVE	1		PAOZZN
			(4240-01-334-6824)			
14/2	88115050	98752	RING, RETAINING SIDE VOICEMITTER	1		PAOZZN
			(5365-01-222-3145)			
15/2	88115041	98752	VOICEMITTER, SIDE	1		PAFZZN
			(4240-01-224-4198)			
16/2	88115049	98752	GASKET, SIDE VOICEMITTER	1		PAOZZN
			(5630-01-260-8702)			
17/2	88115029	98752	DISC, NOSECUP VALVE	2		PAOZZN
			(4240-01-246-1996)			

FIGURE & INDEX/ SHEET NO.	PART NUMBER	CAGE	DESCRIPTION 1234567	UNITS PER ASSY	USABLE ON CODE	SMR CODE
6-1-1/ 18/2	88115035-2	98752	FRONT VOICEMITTER WITH RETAINING RING MCU-2P	1		PAFZZN
19/2	88115053	98752	DRINKING TUBE, INTERNAL (4240-01-286-1843)	1		PAOZZN
20/2	88115030	98752	VALVE, NOSECUP SEAT (4820-01-286-1833)	2		PAOZZN
21	M-101/AIC	16575	MICROPHONE ELEMENT (5965-00-843-9957)	1		PAOZZN
22	LP57N26S5	03038	SCREW, SELF LOCKING (OPTIONAL) (5305-01-040-4682) (NOT ILLUSTRATED)	2		PAOZZN
23/1	864-33	53655	CARRIER, CHEMICAL-BIOLOGICAL FIELD ... MASK (4240-01-224-4196)	1		PAOZZN
24	102950	82872	PLUG CONNECTOR, FEMALE (5935-01-125-4897) (NOT ILLUSTRATED)	1		PAFZZ
25	119563	83058	PLUG CONNECTOR, MALE (5935-00-888-5351) (NOT ILLUSTRATED)	1		PAFZZ
26	31500	82872	CORD ASSY (OPTIONAL) (5995-00-890-8614)	1		PAFZZ
27/1/2	ANPNT-2A	8Y672	INTERCOMMUNICATIONS SET (AUDIO PROJECTION) (OPTIONAL)	1		PEOBZN
	806500	81361	INTERCOMMUNICATIONS SET (AUDIO PROJECTION) (OPTIONAL)	1		PEOBZN
28	00-5989	53655	DUST COVER (1660-01-087-8681) (1660-01-006-3089)	1		PAOZZN
29/2	5-1-2765	81361	SKULL CAP (4240-01-390-3057) (4240-01-442-4810)	1		PAOZZN
30/3	513354	81361	MICROPHONE, DETACHABLE (4240-01-442-4810)	1	B	PAFZZN
	51339	81361	MICROPHONE, DETACHABLE (5965-01-414-2257)			
-	5-1-1059	81361	M40 MASK RETAINING RING FOR SIDE VOICEMITTER (5365-01-260-8700)			

APPENDIX A

INTRODUCTION AND GENERAL INFORMATION

A.1 HGU-65P DESCRIPTION.

HGU-65P Explosive Ordnance Disposal (EOD) Hood (Figure A-1) is made from butyl-coated nylon cloth (MIL-C-12189), with a standard MCU-2 Series mask eyelens outsert bonded into the hood. The rubber strap and clips have been removed from the outsert to enhance bonding and fit. The hood has two shawls to enhance protective ability when worn with the M-3 Toxicological Agents Protective (TAP) suit. The inner shawl is tucked inside M3 TAP suit,

and the outer shawl is draped over the shoulders. The hood has underarm straps and a head retention strap. The retention strap is used to hold the outsert tightly in place over the mask lens. The hood comes in two sizes, short and medium/long. The small hood is designed for use with the short MCU-2 Series mask, and the medium/long is designed for use with both the medium and the long MCU-2 Series masks. This hood is designed to replace the TAP hood currently issued with the M3 TAP suit, and is intended for use by Explosive Ordnance Disposal personnel.

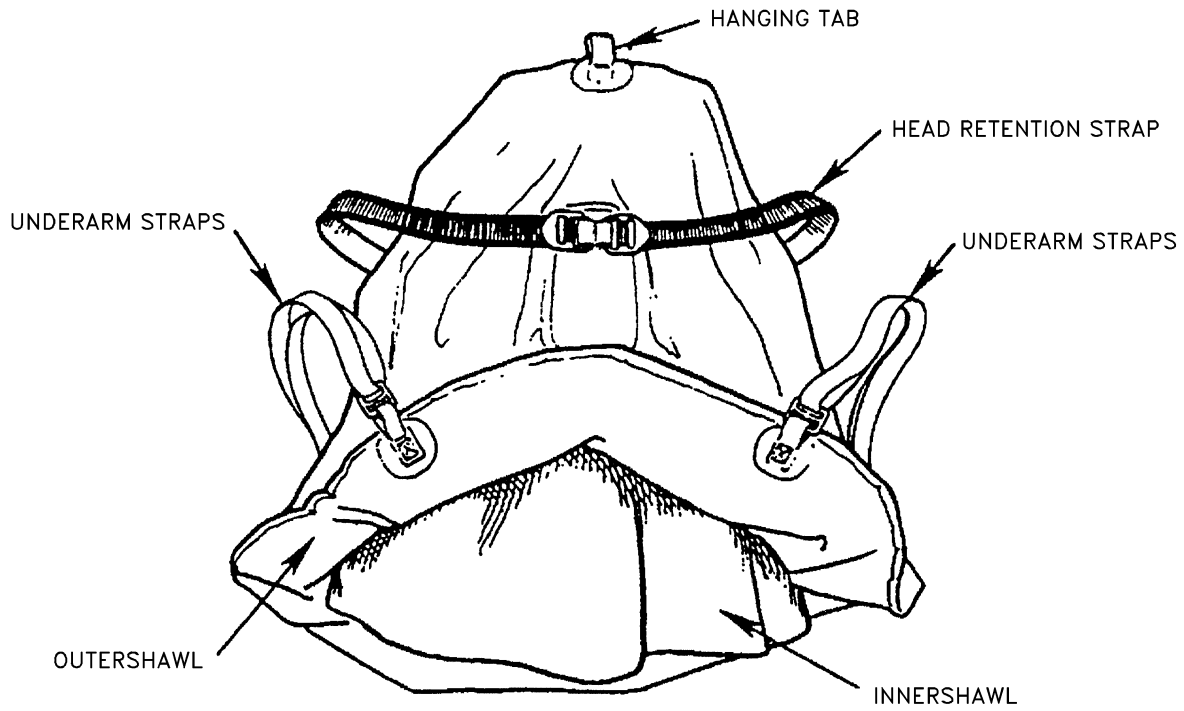
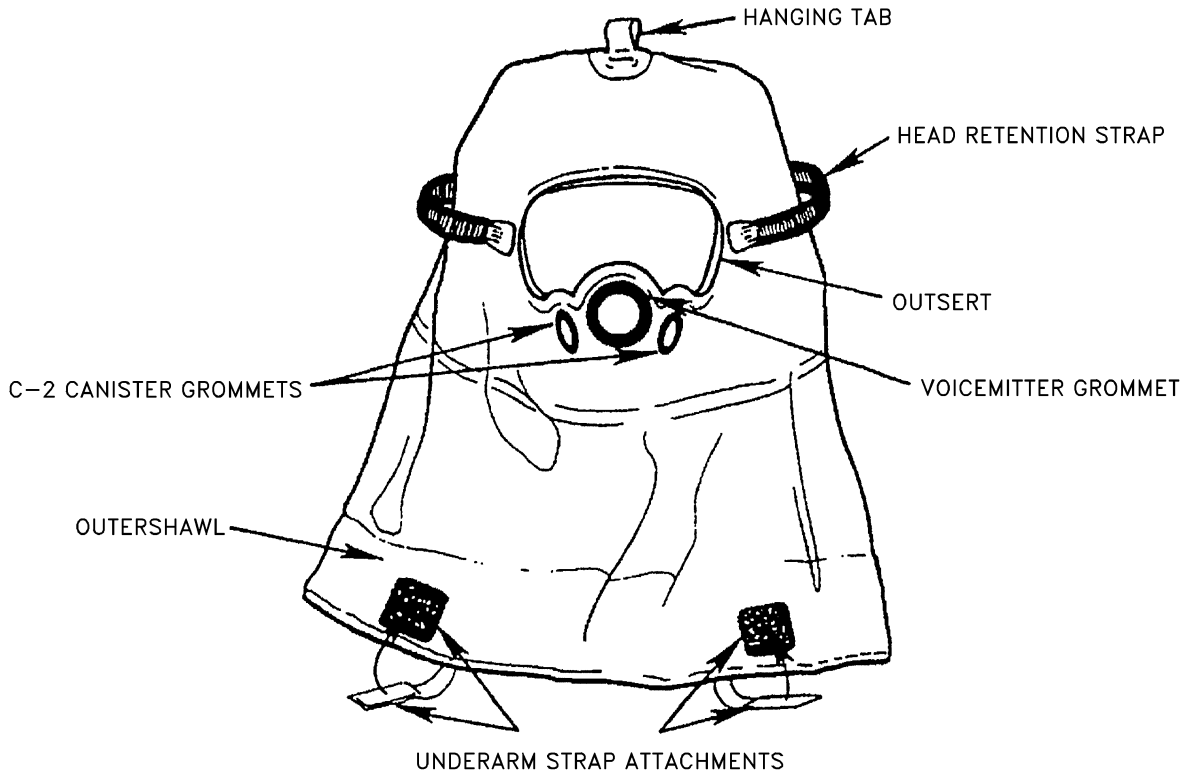

L0004087

Figure A-1. HGU-65P EOD Hood

APPENDIX B

PREPARATION FOR USE AND SHIPMENT

B.1 HGU-65P EXPLOSIVE ORDNANCE DISPOSAL (EOD) HOOD ATTACHMENT.

The HGU-65P must be worn with the MCU-2 Series mask using the dual C-2 canister configuration.



Do not attach the HGU-65P to the MCU-2 Series mask with the eyelens outsert attached. Doing so will result in an improper fit, excessive fogging, and introduce contamination in the hood causing illness or death.

NOTE

You must have another complete inlet valve assembly (Figure 3-6), and two serviceable canisters in order to complete all steps of the following procedures.

- a. Remove the eyelens outsert from the MCU-2 Series mask.
- b. The HGU-65P must be worn with the MCU-2 Series mask using the dual C-2 canister configuration.
 - (1) Remove the old cannister from the mask, if applicable, and dispose of properly.
 - (2) With the straight side of the D-ring on the shoulder strap of the carrier, or with another substitute tool, unscrew the side voicemitter retaining ring (refer to paragraph 3.9).
 - (3) Remove the voicemitter and the gasket.
 - (4) Keep the voicemitter and the retaining ring for reuse.
 - (5) Install the complete new inlet valve assembly into the mask port that did not have the canister (refer to paragraph 3.9).
- c. Wipe both the inside and outside of the MCU-2 Series mask eyelens with the anti-fogging cloth, NSN 6850-00-127-7193, according to the cloth container instructions.
- d. Unfold the HGU-65P EOD Hood and extend straps to maximum outward adjustment.
- e. Make sure the hood is the correct size. The hood comes in two sizes, short and medium/long. Small hoods shall be worn with the short MCU-2 Series mask, and medium/long hoods shall be worn with both the medium and the long MCU-2 Series masks.
- f. Wipe the outer surface of the HGU-65P's outsert with the anti-fogging cloth.
- g. Turn the hood inside out.
- h. Wipe the inner surface of the HGU-65P's eyelens outsert with the anti-fogging cloth.
- i. Position the voicemitter grommet in the hood over the front voicemitter of the mask.
- j. Turn the hood right side out.
- k. From the outside, stretch the voicemitter grommet around the front voicemitter. The grommet should be positioned as shown in Figure B-1. There should be no gaps in the seal around the voicemitter perimeter.
- l. From the outside, push the stem of one new serviceable C-2 canister through the appropriate grommet opening.
- m. Slowly draw the C-2 canister back out until the grommet is positioned as shown in Figure B-2 to ensure grommet material will not be pinched in C-2 canister threads.
- n. Screw the C-2 canister into the inlet valve body and hand tighten.
- o. Repeat steps l., m., and n. for the second C-2 canister.
- p. Visually inspect the entire assembly for integrity.

B.2 STORAGE.

- a. The HGU-65P hood is stored either by the hanging tab or in a fiberboard box with the M3 TAP suit in accordance with T.O. 14P3-1-7, Section IV.
- b. The hood if not hung, must be folded and packed as follows.
- c. Place hood, flat on table with lens facing upward. (Figure B-3, view A).
- d. Attach underarm strap fastening devices and fold straps up under skirt.
- e. Fold skirt sides in toward center as shown in Figure B-3, view B.

T.O. 14P4-15-1

- f. Fold top of hood toward skirt approximately 1/3 of the way down. (Figure B-3, view C).
- g. Fold bottom of hood up over fold just made. Make certain product marking is showing. (Figure B-3, view D).
- h. Place folded hood in with M3 TAP suit in accordance with T.O. 14P3-1-7.

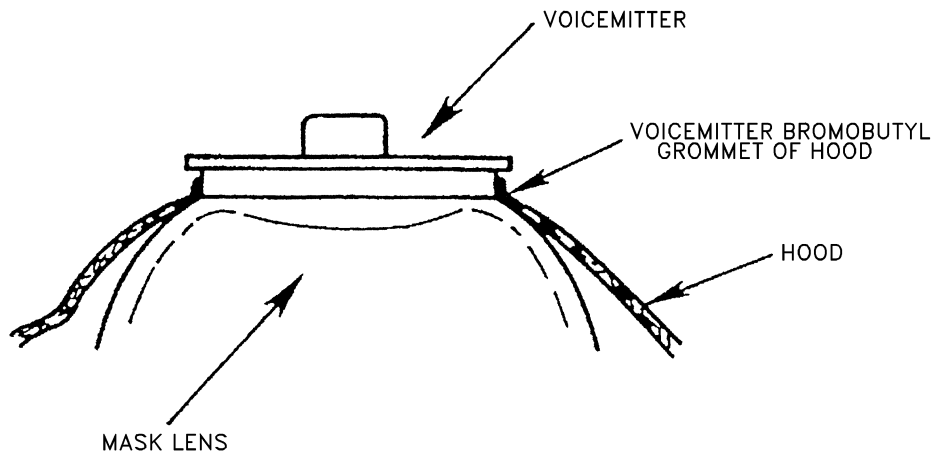

L0004088

Figure B-1. Voicemitter Grommet Position

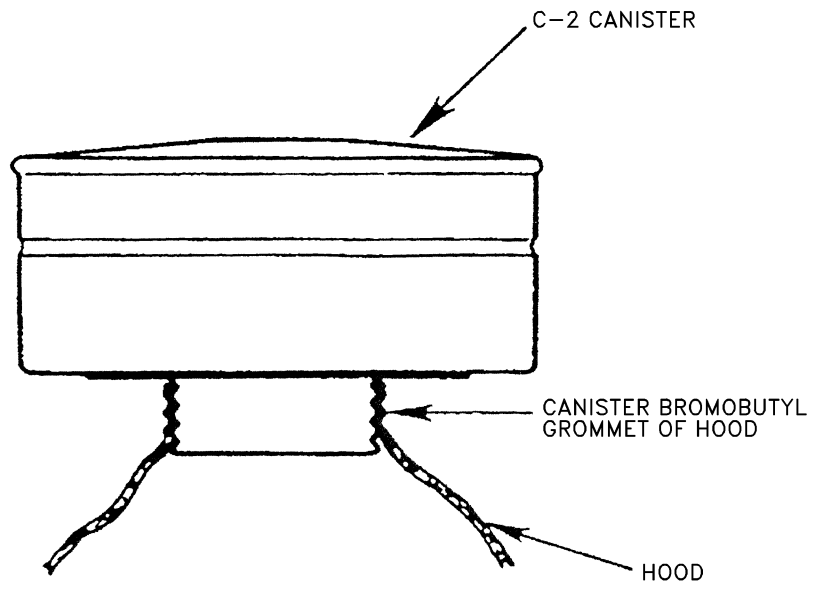

L0004089

Figure B-2. C-2 Canister Grommet Position

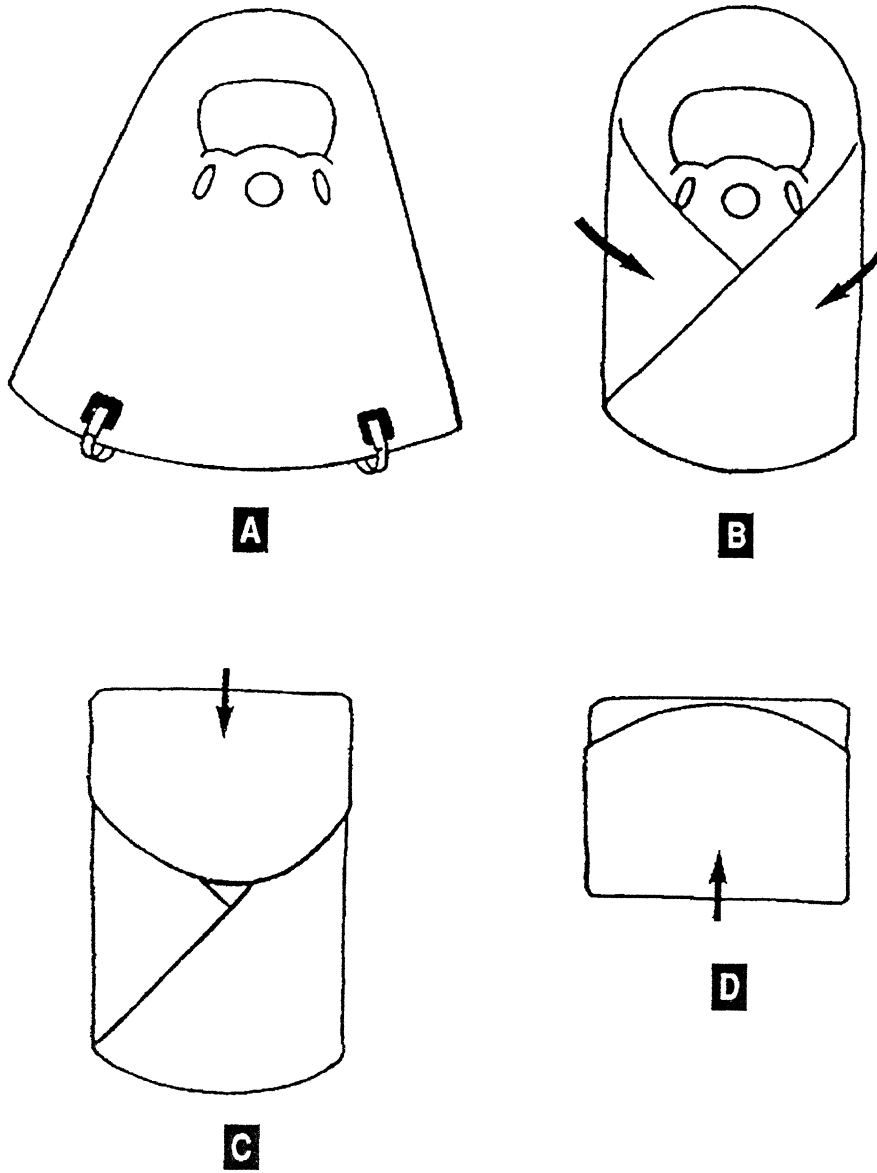

L0004090

Figure B-3. HGU-65P Folding Procedures

APPENDIX C

OPERATION INSTRUCTIONS

C.1 DONNING PROCEDURES FOR MASKS WITH HGU-65P EOD HOODS.



The drinking tube is inaccessible when the HGU-65P EOD Hood is worn with the MCU-2 Series mask. Do not attempt to access the drinking tube. Doing so may expose the wearer to high concentrations of toxic agents, causing illness or death.

NOTE

- These procedures presume the following:
- Unapproved eyewear and/or contact lenses have been removed.
- Appropriate ear protection is in place, if applicable.
- The MCU-2 Series mask temple and forehead straps have been preadjusted (Refer to Chapter 3)
- These procedures assume the following:
- Donning in an uncontaminated environment, using a BUDDY SYSTEM for donning.
- The M3 TAP suit, and/or the M2 TAP apron (as appropriate) has been donned, according to T.O. 60A-1-1-11.

Don the mask/hood assembly in the following steps:

- a. Roll the rear portion of the hood upward to expose the head harness of the mask.
- b. Turn the mask harness inside out over the mask.
- c. Reach inside the hood with one hand and place the outlet valve assembly area in the palm of that hand.



When donning the mask/hood assembly do not block the canisters. The wearer may suffocate if the hood fabric blocks them.

- d. Using the free hand, push forehead hair aside. Place the mask on face forcing the chin cup very

tightly against chin. Pull head harness over head using the quick-don tab.

- e. The buddy will tighten the head harness by grasping a neck strap in each hand and tightening with small jerking motions. The wearer shall indicate the head harness is sufficiently tight both visually and audibly.
- f. The wearer shall perform negative pressure check (Refer to T.O. 14P4-15-1, Chapter 3) to ensure an airtight seal.
- g. With the assistance of the buddy, unroll the rear portion of the hood to cover the back of the head. Drape the hood over the shoulders.

NOTE

The HGU-65P hood outsert must form a seal around the entire perimeter of the MCU-2 Series mask eyelens. Failure to do so will result in an improper fit, which could result in excessive fogging of the outsert.

- h. The buddy will tighten the HGU-65P head retention strap by grasping a strap in each hand and tightening with small jerking motions. The wearer shall indicate the retention strap is sufficiently tight both visually and audibly.
- i. The buddy shall visually inspect the outsert seal to the MCU-2 Series mask eyelens to ensure the seal is touching the eyelens in all places.
- j. If wearing the hood with the M2 Toxicological Agents Protective (TAP) apron only, proceed to step n. If wearing the hood with the M3 TAP suit, proceed to the following step.
- k. Using both hands, the wearer will raise the outer shawl off the shoulders.
- l. The buddy will tuck the inner shawl into the M3 TAP suit, minimizing bunching of the inner shawl fabric by making one or two smooth folds.
- m. The buddy will pull the M3 TAP suit up over the wearer's shoulders, and finish closure of the TAP suit (refer to T.O. 60A-1-1-11).
- n. The wearer and buddy will place the outer shawl over the wearer's shoulders.
- o. The buddy will pass the straps under the wearer's arms and fasten the straps to the front of the outer shawl by pressing the two parts of the fastening

T.O. 14P4-15-1

device together. Adjust the straps as necessary to obtain a comfortable fit.

C.2 DOFFING PROCEDURES FOR MASKS WITH HGU-65P EOD HOODS.

This procedure assumes the use of the buddy system in doffing the mask and hood. This procedure also assumes the M3 TAP suit, and/or the M2 TAP apron (as appropriate) has been removed. The underarm straps should, therefore, already be unfastened.

- a. The buddy will loosen the HGU-65P head retention straps.

WARNING

When doffing the mask/hood assembly do not block the canisters. The wearer may suffocate if the hood fabric blocks them.

- b. Roll the back of the two shawls forward over the head and leave the hood suspended from the front of the mask. Do not block the canisters with the rolled up hood.
- c. The buddy will loosen the mask neck straps. The wearer will grasp the mask in the outlet valve area (without reaching inside the reversed hood) and remove by pulling down, outward, and up.

C.3 HGU-65/P CLEANING.

- a. Uncontaminated.
 - (1) Unscrew and remove both C-2 canisters.
 - (2) Separate hood from mask (in reverse order of hood attachment).

- (3) Wash by hand in warm water using mild soap.
- (4) Rinse in cool water and hang in open air to dry.

- b. Fuming nitric acid exposure.

- (1) Wash thoroughly in water.
- (2) Sponge off with a 5 to 10 percent sodium bicarbonate solution.
- (3) Rinse thoroughly with clear water and hang in open air to dry.

- c. Hydrazine/UDMH or nitrogen tetroxide exposure.

- (1) Wash with household laundry detergent and water solution.
- (2) Rinse thoroughly with clear water and hang in open air to dry.

CAUTION

Damage to the HGU 65P's outsert will occur if decontaminated using personal decon kits. Decontaminate according to T.O. 11C15-1-3 and T.O. 60A-1-1-11.

- d. Chemical warfare agent decontamination.

C.4 MCU-2 SERIES MASK CLEANING.

Refer T.O. 14P4-15-1, Chapter 5.

APPENDIX D MAINTENANCE INSTRUCTIONS

D.1 INSPECTION AND PREVENTIVE MAINTENANCE OF THE HGU-65P EOD HOOD.

- a. After removal from packaging, the HGU-65P shall be inspected:
 - (1) Upon issue to the individual, by the individual.
 - (2) Prior to each use.
 - (3) Annually during peace-time.
 - (4) Wartime - as directed.
- b. Visual inspection shall be performed in well-lit areas.
- c. Seam testing shall be accomplished by pull testing using the thumb and finger.
- d. Table D-1 provides a list of items to be checked, inspection procedures, and a corrective action.
- e. Unserviceable HGU-65P EOD Hoods may be used for training purposes. Use of such hoods will be restricted to area of training which will not subject the wearer to any hazardous conditions. Identification of unserviceable HGU-65P EOD Hoods shall be as follows: Using indelible waterproof ink, marking, white, NSN 7510-00-161-0185, stencil the words FOR TRAINING USE ONLY across the back of the outer shawl in one-inch letters.

Table D-1. Inspection and Preventive Maintenance Checks

ITEM	PERIOD	INSPECT FOR	CORRECTIVE ACTION
PackagedHood	Annually	Ripped, torn, or punctured package; Seams unsealed	If material under the package tear is damaged, call item Manager for disposal. If undamaged, repackage in heat seal or ziplock bag.
ONCE REMOVED FROM PACKAGE			
Outsert	Prior to use and annually	Cracked, broken, or missing lens; Severely scratch lens -obstructs/distorts vision: Visual inspection.	Replace the hood.
Hood Material (including black butyl material)	Prior to use and annually	Holes, cuts, rips, tears. Visual inspection.	Replace the hood.
Seam, except hem seam	Prior to use and annually	Seam separation from hood material; Seam separation from black butyl material; Seam separation from outsert; Visual inspection and pull test (as necessary).	Replace the hood.

D.2 REPAIR.

There are no parts of the HGU-65P EOD Hood which require repair. Unserviceable hoods are replaced.

